

FLEX

OPERATOR'S MANUAL

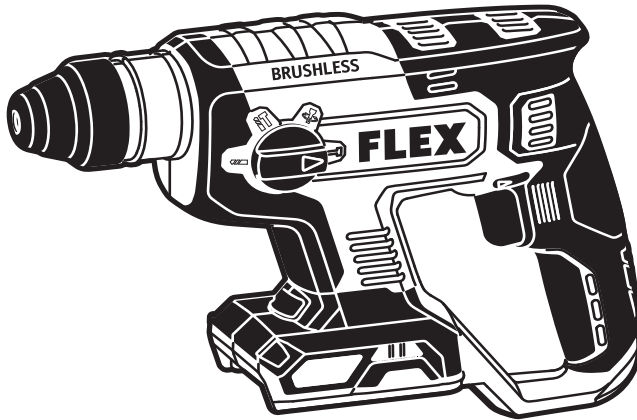

Model: FXA1531

24V BRUSHLESS ROTARY HAMMER

⚠ WARNING: To reduce the risk of injury, the user must read and understand the Owner's Manual before using this product. Save these instructions for future reference.



Please contact FLEX customer service in Australia 1300 000 346 or
New Zealand 0508 000 346 any time you have questions or warranty claims.

SAFETY SYMBOLS

The purpose of safety symbols is to attract your attention to possible dangers. The safety symbols and the explanations with them deserve your careful attention and understanding. The symbol warnings do not, by themselves, eliminate any danger. The instructions and warnings they give are no substitutes for proper accident prevention measures.

⚠ WARNING Be sure to read and understand all safety instructions in this Owner's Manual, including all safety alert symbols such as "**DANGER**," "**WARNING**," and "**CAUTION**" before using this tool. Failure to follow all instructions listed below may result in electric shock, fire, and/or serious personal injury.

The definitions below describe the level of severity for each signal word. Please read the manual and pay attention to these symbols.



This is the safety alert symbol. It is used to alert you to potential personal injury hazards. Obey all safety messages that follow this symbol to avoid possible injury or death.



DANGER indicates a hazardous situation which, if not avoided, will result in death or serious injury.



WARNING indicates a hazardous situation which, if not avoided, could result in death or serious injury.



CAUTION, used with the safety alert symbol, indicates a hazardous situation which, if not avoided, will result in minor or moderate injury.

GENERAL POWER TOOL SAFETY WARNINGS



WARNING Read all safety warnings, instructions, illustrations and specifications provided with this power tool. Failure to follow all instructions listed below may result in electric shock, fire and/or serious injury.

SAVE ALL WARNINGS AND INSTRUCTIONS FOR FUTURE REFERENCE.

The term “power tool” in the warnings refers to your mains-operated (corded) power tool or battery-operated (cordless) power tool.

Work area safety

Keep work area clean and well lit. Cluttered or dark areas invite accidents.

Do not operate power tools in explosive atmospheres, such as in the presence of flammable liquids, gases or dust. Power tools create sparks which may ignite the dust or fumes.

Keep children and bystanders away while operating a power tool. Distractions can cause you to lose control.

Electrical safety

Power tool plugs must match the outlet. Never modify the plug in any way. Do not use any adapter plugs with earthed (grounded) power tools. Unmodified plugs and matching outlets will reduce risk of electric shock.

Avoid body contact with earthed or grounded surfaces, such as pipes, radiators, ranges and refrigerators. There is an increased risk of electric shock if your body is earthed or grounded.

Do not expose power tools to rain or wet conditions. Water entering a power tool will increase the risk of electric shock.

Do not abuse the cord. Never use the cord for carrying, pulling or unplugging the power tool. Keep cord away from heat, oil, sharp edges or moving parts. Damaged or entangled cords increase the risk of electric shock.

When operating a power tool outdoors, use an extension cord suitable for outdoor use. Use of a cord suitable for outdoor use reduces the risk of electric shock.

If operating a power tool in a damp location is unavoidable, use a residual current device (RCD) protected supply. Use of an RCD reduces the risk of electric shock.

Personal safety

Stay alert, watch what you are doing and use common sense when operating a power tool. Do not use a power tool while you are tired or under the influence of drugs, alcohol or medication. A moment of inattention while operating power tools may result in serious personal injury.

Use personal protective equipment. Always wear eye protection. Protective equipment such as a dust mask, non-skid safety shoes, hard hat or hearing protection used for appropriate conditions will reduce personal injuries.

Prevent unintentional starting. Ensure the switch is in the off-position before connecting to power source and/or battery pack, picking up or carrying the tool. Carrying power tools with your finger on the switch or energizing power tools that have the switch on invites accidents.

Remove any adjusting key or wrench before turning the power tool on. A wrench or a key left attached to a rotating part of the power tool may result in personal injury.

Do not overreach. Keep proper footing and balance at all times. This enables better control of the power tool in unexpected situations.

Dress properly. Do not wear loose clothing or jewelry. Keep your hair and clothing away from moving parts. Loose clothes, jewelry or long hair can be caught in moving parts.

If devices are provided for the connection of dust extraction and collection facilities, ensure these are connected and properly used. Use of dust collection can reduce dust-related hazards.

Do not let familiarity gained from frequent use of tools allow you to become complacent and ignore tool safety principles. A careless action can cause severe injury within a fraction of a second.

Power tool use and care

Do not force the power tool. Use the correct power tool for your application. The correct power tool will do the job better and safer at the rate for which it was designed.

Do not use the power tool if the switch does not turn it on and off. Any power tool that cannot be controlled with the switch is dangerous and must be repaired.

Disconnect the plug from the power source and/or remove the battery pack, if detachable, from the power tool before making any adjustments, changing accessories, or storing power tools. Such preventive safety measures reduce the risk of starting the power tool accidentally.

Store idle power tools out of the reach of children and do not allow persons unfamiliar with the power tool or these instructions to operate the power tool. Power tools are dangerous in the hands of untrained users.

Maintain power tools and accessories. Check for misalignment or binding of moving parts, breakage of parts and any other condition that may affect the power tool's operation. If damaged, have the power tool repaired before use. Many accidents are caused by poorly maintained power tools.

Keep cutting tools sharp and clean. Properly maintained cutting tools with sharp cutting edges are less likely to bind and are easier to control.

Use the power tool, accessories and tool bits etc. in accordance with these instructions, taking into account the working conditions and the work to be performed.

Use of the power tool for operations different from those intended could result in a hazardous situation.

Keep handles and grasping surfaces dry, clean and free from oil and grease. Slippery handles and grasping surfaces do not allow for safe handling and control of the tool in unexpected situations.

Battery tool use and care

Recharge only with the charger specified by the manufacturer. A charger that is suitable for one type of battery pack may create a risk of fire when used with another battery pack.

Use power tools only with specifically designated battery packs. Use of any other battery packs may create a risk of injury and fire.

When battery pack is not in use, keep it away from other metal objects, like paper clips, coins, keys, nails, screws or other small metal objects, that can make a connection from one terminal to another. Shorting the battery terminals together may cause burns or a fire.

Under abusive conditions, liquid may be ejected from the battery; avoid contact. If contact accidentally occurs, flush with water. If liquid contacts eyes, additionally seek medical help. Liquid ejected from the battery may cause irritation or burns.

Do not use a battery pack or tool that is damaged or modified. Damaged or modified batteries may exhibit unpredictable behavior resulting in fire, explosion or risk of injury.

Do not expose a battery pack or tool to fire or excessive temperature. Exposure to fire or temperature above 130°C may cause explosion.

Follow all charging instructions and do not charge the battery pack or tool outside the temperature range specified in the instructions. Charging improperly or at temperatures outside the specified range may damage the battery and increase the risk of fire.

Service

Have your power tool serviced by a qualified repair person using only identical replacement parts. This will ensure that the safety of the power tool is maintained.

Never service damaged battery packs. Service of battery packs should only be performed by the manufacturer or authorized service providers.

SAFETY WARNINGS FOR HAMMER

Safety instructions for all operations:









- **Wear ear protectors when impact drilling.** Exposure to noise can cause hearing loss.
- **Hold the power tool by insulated gripping surfaces, when performing an operation where the cutting tool may contact hidden wiring.** Cutting tools contacting a “live” wire may make exposed metal parts of the power tool “live” and could give the operator an electric shock.
- **Use auxiliary handle(s), if supplied with the tool.** Loss of control can cause personal injury.
- **Secure the work piece.** Clamping devices or a vise will hold the work piece in place better and more safely than holding it by hand.
- **Do not drill, fasten or break into existing walls or other blind areas where electrical wiring may exist.** If this situation is unavoidable, disconnect all fuses or circuit breakers feeding this worksite.
- **Position yourself to avoid being caught between the tool or side handle and walls or posts.** Should the bit become bound or jammed in the work, the reaction torque of the tool could crush your hand or leg.



Safety instructions when using long drill bits with rotary hammers:

- Never operate at higher speed than the maximum speed rating of the drill bit. At higher speeds, the bit is likely to bend if allowed to rotate freely without contacting the workpiece, resulting in personal injury.
- Always start drilling at low speed and with the bit tip in contact with the workpiece.
- At higher speeds, the bit is likely to bend if allowed to rotate freely without contacting the workpiece, resulting in personal injury.
- Apply pressure only in direct line with the bit and do not apply excessive pressure. Bits can bend causing breakage or loss of control, resulting in personal injury.

SYMBOLS

IMPORTANT: Some of the following symbols may be used on your tool. Please study them and learn their meaning. Proper interpretation of these symbols will allow you to operate the tool better and safer.

Symbol	Name	Designation/Explanation
V	Volts	Voltage
A	Amperes	Current
Hz	Hertz	Frequency (cycles per second)
W	Watt	Power
kg	Kilograms	Weight
min	Minutes	Time
s	Seconds	Time
Wh	Watt-hours	Battery capacity
Ah	Ampere-hours	Battery capacity
∅	Diameter	Size of drill bits, grinding wheels, etc.
n_0	No load speed	Rotational speed, at no load
n	Rated speed	Maximum attainable speed
.../min	Revolutions or reciprocations per minute (rpm)	Revolutions, strokes, surface speed, orbits, etc. per minute
O	Off position	Zero speed, zero torque...
1,2,3,... I,II,III,	Selector settings	Speed, torque, or position settings. Higher number means greater speed
	Infinitely variable selector with off	Speed is increasing from 0 setting
	Arrow	Action in the direction of arrow
	Alternating current (AC)	Type or a characteristic of current
	Direct current (DC)	Type or a characteristic of current
	Alternating or direct current (AC / DC)	Type or a characteristic of current
	Class II tool	Designates Double Insulated Construction tools.
	Disposal information for the old machine	Do not throw electric power tools into the household waste!
	Read the instructions	Alerts user to read manual

Symbol	Name	Designation/Explanation
	Wear eye protection symbol	Alerts user to wear eye protection
	Regulatory compliance mark	This product complies with applicable Australian standards.

FUNCTIONAL DESCRIPTIONS AND SPECIFICATIONS

Rotary Hammer

Fig. 1

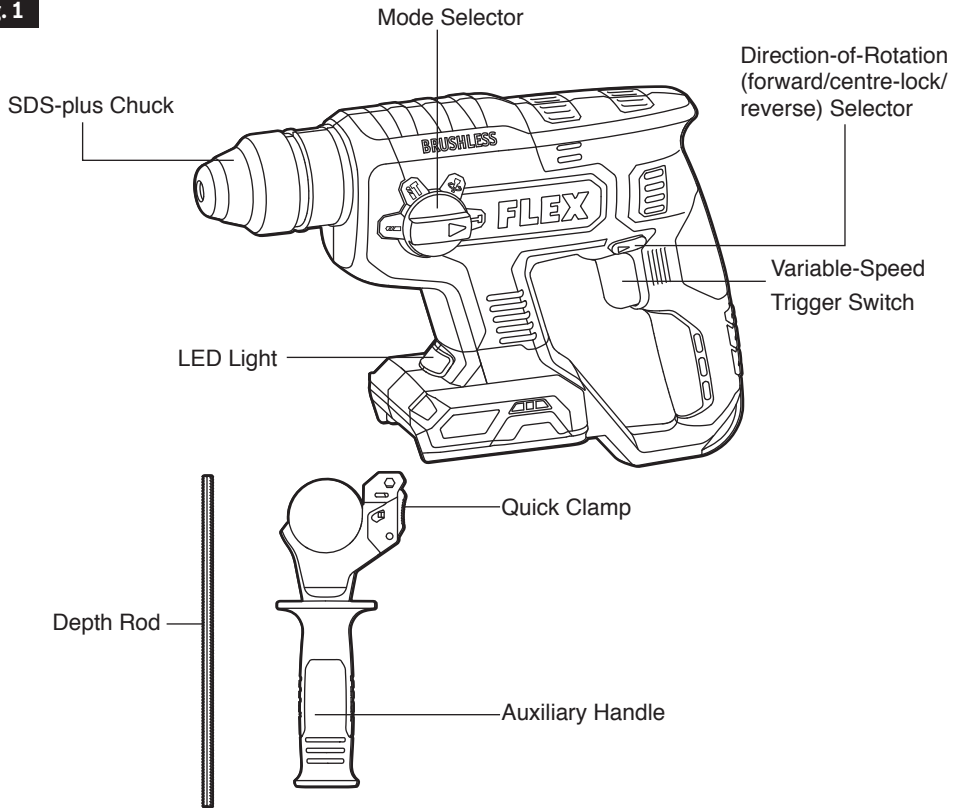

Model No.	FXA1531
Rated Voltage	24 V d.c.
Chuck Size/Type	SDS-plus
No-load Speed	0-1400 /min (RPM)
Impact Rate	0-4500 /min (BPM)
Recommended operating temperature	-20 – 40°C
Recommended storage temperature	< 50°C

Intended Use

This tool is intended

- for hammer drilling in concrete, brick and stone,
- for drilling without impact in wood, metal, ceramic and plastic.

ASSEMBLY

⚠ WARNING Detach the battery pack from the tool before performing any assembly or adjustments, or changing accessories. Such preventive safety measures reduce the risk of starting the tool accidentally.

TO ATTACH/DETACH BATTERY PACK (FIG. 2)

Lock "OFF" the variable-speed trigger switch on the tool by placing the direction-of-rotation (forward/centre-lock/reverse) selector in the centre position before attaching or detaching the battery pack.

To attach the battery pack:

Align the raised rib on the battery pack with the groove in the tool, and then slide the battery pack onto the tool.

NOTICE: When placing the battery pack onto the tool, be sure that the raised rib on the battery pack aligns with the groove inside the tool and that the latches snap into place properly. Improper attachment of the battery pack can cause damage to internal components.

To detach the battery pack:

Depress the battery-release button located on the front of the battery pack to release the battery pack. Pull the battery pack out and remove it from the tool.

Fig. 2

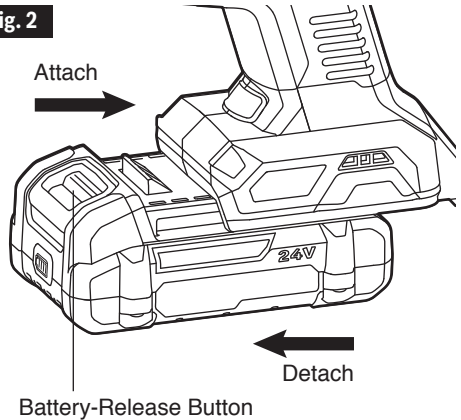

⚠ WARNING Battery tools are always in operating condition. Therefore, the direction-of-rotation (forward/centre-lock/reverse) selector should always be locked in the centre position when the tool is not in use or while carrying the tool at your side.

⚠ WARNING Do not attempt to modify this tool or create accessories not recommended for use with this tool. Any such alteration or modification is misuse and could result in a hazardous condition leading to possible serious injury.

INSTALL AND REMOVE ACCESSORIES (FIG. 3 AND 4)

⚠ WARNING Do not use bits with damaged shanks.

Your tool is equipped with an SDS-plus chuck. Lock the trigger switch "OFF" on the tool by placing the direction-of-rotation selector in the centre position.

To install the accessory (Fig. 3):

- Clean the accessory and lightly lubricate it before inserting it into the chuck.
- Insert the accessory in the SDS-plus chuck while turning and pushing it until it engages. The accessory locks in position automatically.
- Check to ensure that the accessory is locked in place.

Fig. 3

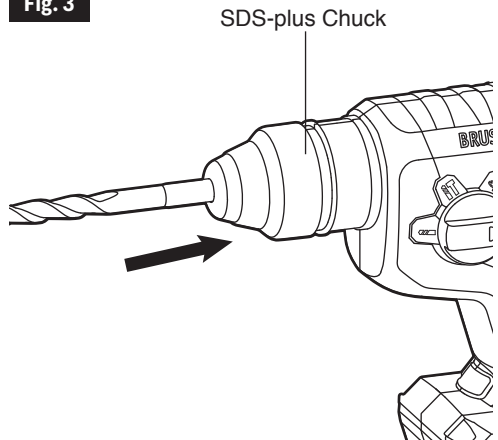

To remove the accessory (Fig. 4):

⚠ WARNING Use protective gloves when removing the bit from the tool, or first allow the bit to cool down. The bit may be hot after prolonged use.

- Pull back the locking sleeve and remove the accessory from the chuck.

Fig. 4

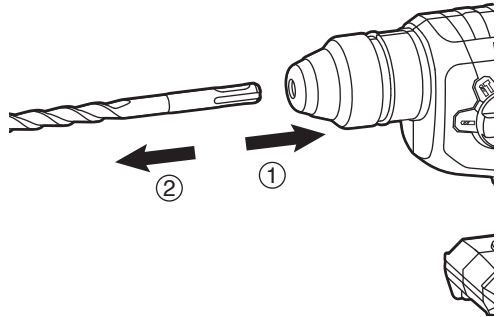

AUXILIARY HANDLE (FIG. 5)

The tool must be supported with the auxiliary handle, which can be swiveled 360°.

To reposition and/or swivel the handle, rotate the grip to loosen it, move the handle to the desired position, and securely retighten the grip.

⚠ WARNING For safety and ease of operation, securely tighten the auxiliary handle by turning the handle clockwise before every use.

Fig. 5

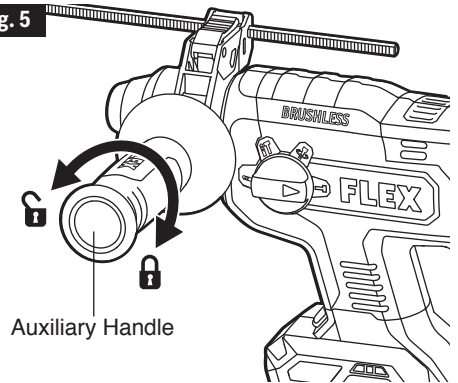

DEPTH ROD (FIG. 6)

- Depress the upper part of the quick clamp, and then insert the depth rod through the opening.
- Set the depth rod to the desired drilling depth.
- Release the quick clamp to lock the depth rod in position.

Fig. 6

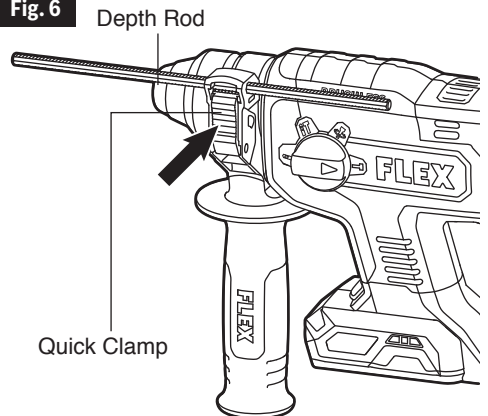

ADJUSTMENTS

DIRECTION-OF-ROTATION (FORWARD/CENTRE-LOCK/REVERSE) SELECTOR

⚠ WARNING After tool use, lock the direction-of-rotation selector in the “OFF” position (centre-lock) to help prevent accidental starts and possible injury.

Your tool is equipped with a direction-of-rotation selector, located above the variable-speed trigger switch. This selector is used to change the direction of rotation of the bit and to lock the variable-speed trigger in the “OFF” (centre-lock) position.

- Position the direction-of-rotation selector to the far left of the tool to drill holes (Fig. 7).
- Position the direction-of-rotation selector to the far right of the tool to remove drill bit from holes (Fig. 7).
- Position the switch in the “OFF” (centre-lock) position to help reduce the possibility of accidental starting when not in use.

Fig. 7

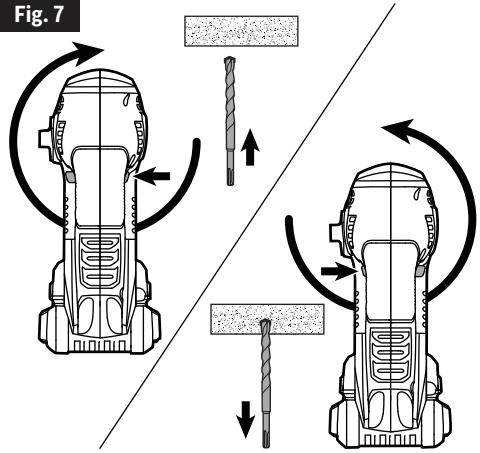

NOTICE: To prevent gear damage, always allow the tool to come to a complete stop before changing the direction of rotation.

NOTICE: The tool will not run unless the direction-of-rotation selector is engaged fully to the left or to the right.

LED LIGHT (FIG. 8)

Your tool is equipped with an LED light, located on the base of the tool. This provides additional light on the surface of the workpiece for operation in lower-light areas.

The LED light will automatically turn on with a slight squeeze on the variable-speed trigger switch before the tool starts running and will turn off approximately 10 seconds after the variable-speed trigger switch is released.

The LED light will rapidly flash when the tool and/or battery pack becomes overloaded or too hot, and the internal sensors will turn the tool off. Rest the tool for a while or place the tool and battery pack separately under air flow to cool them.

The LED light will flash more slowly to indicate that the battery is at low-battery capacity. Recharge the battery pack.

Fig. 8

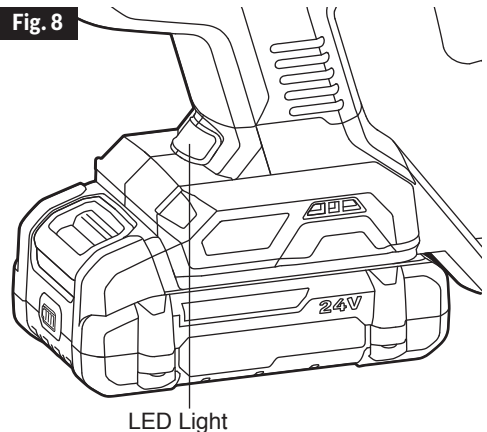

OPERATING INSTRUCTIONS

⚠ WARNING If any parts are damaged or missing, do not operate this product until the parts are replaced. Use of this product with damaged or missing parts could result in serious personal injury.

⚠ WARNING To prevent accidental starting that could cause serious personal injury, always remove the battery pack from the tool when assembling parts.

This brushless rotary hammer must be used only with the FLEX 24V series battery packs and chargers.

NOTICE: Please refer to the battery pack and charger manuals for detailed operating information.

VARIABLE-SPEED TRIGGER SWITCH (FIG. 9)



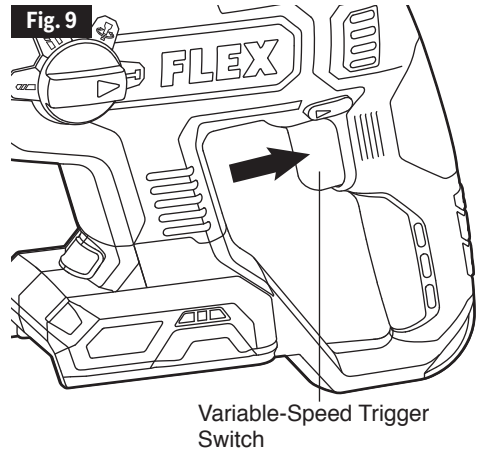

Your tool is equipped with a variable-speed trigger switch. The tool can be turned “ON” or “OFF” by depressing or releasing the variable-speed trigger switch.

The variable-speed trigger switch delivers higher speed with increased trigger pressure and lower speed with decreased trigger pressure.



MODE SELECTOR (FIG. 10)

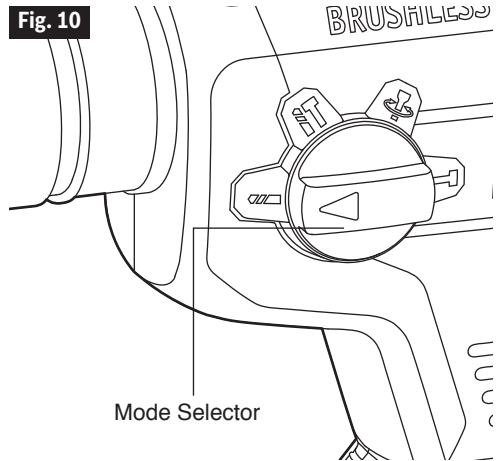

The operation of the gearbox for each application is set with the mode selector. To change among functions, slide and rotate the selector to the desired operating mode.

Rotary Drilling Mode	
Hammer Drilling Mode	
Working Angle Adjustment for Chisel Bits	
Hammering Mode	



SETTING THE CHISEL POSITION (FIG. 11)

The chisel can be turned to a position that is ideal for the work to be performed.

- Move the mode selector to the symbol .
- Turn the chisel until it is at the required angle.
- Move the mode selector to the symbol . Make sure that it audibly clicks into place.

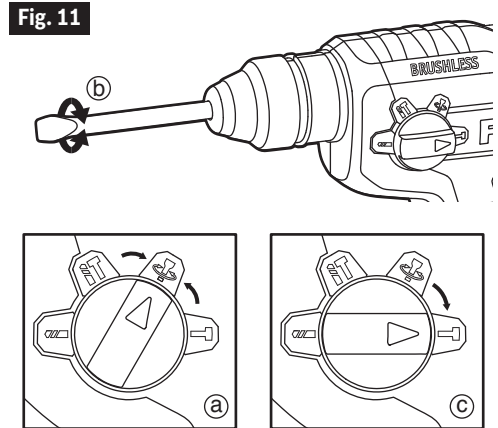

DRILLING MASONRY (HAMMER DRILLING MODE)

For maximum performance, use carbide-tipped masonry bits when drilling holes in brick, concrete, etc. and set the mode selector to the hammer drilling mode .

a. Maintain a speed and a pressure that allow cutting without overheating the bit or drill.

Applying too much pressure will:

- Overheat the drill.
- Wear the bearings.
- Bend or burn bits.

- Produce off-centre or irregular-shaped holes.
- b. Apply light pressure and medium speed for best results in brick.
- c. Apply additional pressure for hard materials, such as concrete.
- d. Begin drilling at a very low speed to prevent the bit from slipping off the starting point.

DRILLING

 **WARNING** Always wear safety goggles or safety glasses with side shields during power tool operation or when blowing dust. If operation is dusty, also wear a dust mask.

- Check that the direction-of-rotation selector is at the correct setting (forward or reverse).
- Secure the material to be drilled in a vise or with clamps to keep it from turning as the drill bit rotates.
- Hold the drill firmly and place the bit at the point to be drilled.
- Depress the variable-speed trigger switch to start the drill.
- Move the drill bit into the workpiece, applying only enough pressure to keep the bit "biting". Do not force the drill or apply side pressure to elongate a hole. Let the tool do the work.
- When drilling hard, smooth surfaces, use a centre punch to mark the desired location of the hole. This will prevent the drill bit from slipping off-centre as the hole is started.

- When drilling metals, use light oil on the drill bit to keep it from overheating. The oil will prolong the life of the bit and increase the drilling action.
- If the bit jams in the workpiece or if the drill stalls, stop the tool immediately. Remove the bit from the workpiece and determine the reason for jamming.

There are two rules for drilling hard materials. First, the harder the material, the greater the pressure you need to apply to the tool. Second, the harder the material, the slower the speed should be. If the hole to be drilled is fairly large, drill a smaller hole first, and then enlarge to the required size with a larger bit; it's often faster in the long run.

DRILLING WOOD (ROTARY DRILLING MODE) (FIG. 12)

For maximum performance, use high-speed steel or brad-point bits for wood drilling, and set the mode selector to the rotary drilling mode .

- Begin drilling at a very low speed to prevent the bit from slipping off the starting point.
- Increase speed as the drill bit bites into the material.
- When drilling “through” holes, place a block of wood behind the workpiece to prevent ragged or splintered edges on the back side of the hole (Fig. 12).

NOTICE: Bits may overheat unless pulled out frequently to clear chips from flutes.

Fig. 12

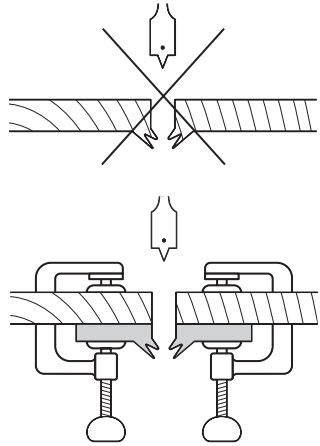

DRILLING METAL (ROTARY DRILLING MODE)

For maximum performance, use high-speed steel bits for drilling metal or steel, and set the mode selector to the rotary drilling mode .

- When drilling metals, use light oil on the drill bit to keep it from overheating. The oil will prolong the life of the bit and increase the drilling action.

- Begin drilling at a very low speed to prevent the bit from slipping off the starting point.
- Maintain a speed and a pressure that allow cutting without overheating the bit. Applying too much pressure will:
 - Overheat the drill.
 - Wear the bearings.
 - Bend or burn bits.
 - Produce off-centre or irregularly shaped holes.

DRILLING TILE (ROTARY DRILLING MODE)

For maximum performance, use high-speed steel bits for drilling in tile, and set the mode selector to the rotary drilling mode.

- When drilling holes in tile, practice on a scrap piece to determine the best speed and pressure. Set the tool to rotary drilling mode.
- Applying adhesive tape to the drilling site can reduce slipping and cracking.
- Begin drilling at a very low speed to prevent the bit from slipping off the starting point.

TIPS FOR DRILLING OPERATION (FIG. 13)

Fig. 13

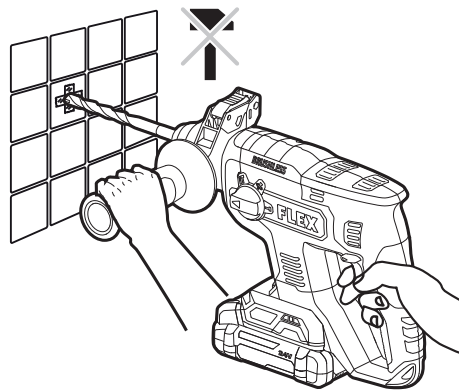

MAINTENANCE

⚠ WARNING To avoid serious personal injury, always remove the battery pack from the tool when cleaning or performing any maintenance.

SERVICE

⚠ WARNING Preventive maintenance performed by unauthorized personnel may result in misplacing of internal wires and components which could cause a serious hazard. We recommend that all tool service be performed by a FLEX Factory Service Centre or Authorized FLEX Service Station.

GENERAL MAINTENANCE

⚠ WARNING When servicing, use only identical replacement parts. Use of any other parts could create a hazard or cause product damage. Periodically inspect the entire product for damaged, missing, or loose parts such as screws, nuts, bolts, caps, etc. Tighten securely all fasteners and caps and do not operate this product until all missing or

damaged parts are replaced. Please contact customer service or an authorized service centre for assistance.

CLEANING

⚠ WARNING The tool may be cleaned most effectively with compressed dry air. Always wear safety goggles when cleaning tools with compressed air. Ventilation openings and switch levers must be kept clean and free of foreign matter. Do not attempt to clean by inserting pointed objects through openings.

⚠ WARNING Certain cleaning agents and solvents damage plastic parts. Some of these are: gasoline, carbon tetrachloride, chlorinated cleaning solvents, ammonia and household detergents that contain ammonia.

STORAGE

Store the tool indoors in a place that is inaccessible to children. Keep away from corrosive agents.

ACCESSORIES

⚠ WARNING The use of any other accessories not specified in this manual may create a hazard.

Depth Guide

Side Handle

WARRANTY STATEMENT

Chervon Australia Pty Ltd (ABN 36 165 077 501) of Unit 14,5 Kelletts Road, Rowville, Victoria, 3178, and Chervon New Zealand Subsidiary Ltd (NZBN 9429049277616) (**Chervon**) provides the following warranty (**Warranty**) to original domestic purchasers in Australia and New Zealand as applicable (**Customers**) of its FLEX24V Tools, FLEX24V Batteries and Chargers and FLEX STACK PACK Storage System (collectively **Products**).

The benefits of this Warranty are in addition to any rights and remedies imposed by Australian State and Federal or New Zealand legislation that cannot be excluded. Nothing in this Warranty is to be interpreted as excluding, restricting or modifying any legislation relevant to the supply of goods and services in Australia or New Zealand, as applicable, which cannot be excluded, restricted or modified. In Australia, if the claimant is a “consumer” under the Australian Consumer Law, Chervon confirms the following:

Our goods come with guarantees that cannot be excluded under the Australian Consumer Law. You are entitled to a replacement or refund for a major failure and compensation for any other reasonably foreseeable loss or damage. You are also entitled to have the goods repaired or replaced if the goods fail to be of acceptable quality and the failure does not amount to a major failure.

WARRANTY

Chervon warrants that, subject to the terms of this Warranty and the exclusions and limitations contained herein, the Products will be free from defects in materials and workmanship for the following period, as applicable, calculated from the date of purchase of the Product (**Warranty Period**):

- If the Customer registers its purchase of the Product online at www.flex-tools.com.au or by calling 1300 000 346 in Australia or www.flex-tools.co.nz or by calling 0508 000 346 in New Zealand within 30 days of the date of its purchase (**Registration**), the Warranty Period for the following Products is as follows:
 - FLEX 24V Tools: 5 years;
 - FLEX 24V Batteries and Chargers: 5 years;
 - FLEX Stack Pack™ Storage System: 1 year;
 - FLEX Accessories & Consumables: 90Days
- If the Customer fails to complete Registration as outlined above, the Warranty Period for the following Products is as follows:
 - FLEX 24V Tools: 3 years;
 - FLEX 24V Batteries and Chargers: 3 years;
 - FLEX Stack Pack™ Storage System: 1 year;
 - FLEX Accessories & Consumables: 90 Days

For further clarification and avoidance of doubt please refer to the FLEX product warranty table included below.

If, before the end of the Warranty Period, a defect appears in the manufacture or assembly of a Product, and Chervon finds the Product to be defective in materials or workmanship, it will, in its sole discretion, either:

- replace or repair the Product or the defective part of the Product free of charge; or
- cause the Product or the defective part of the Product to be replaced or repaired free of charge.

Chervon reserves the right to replace a defective Product or part of a Product with parts and components of similar quality, grade and composition where an identical part or component is not available. Where the product is repaired, Chervon may use refurbished parts.

WARRANTY CLAIMS

1. If a defect covered by Warranty appears, you must first contact Chervon:
 - a) by telephone on 1300 000 346 (AU); or 0508 000 346 (NZ); or
 - b) by email at support@flex-tools.com.au.
2. Any Warranty claim must be accompanied by:
 - a) proof of purchase;
 - b) full details of the alleged defect;
 - c) photo evidence of the alleged defect; and
 - d) any other relevant documents.
3. You must allow Chervon or its authorised agent to inspect and test the Product. If that inspection and test finds no defect in the Product, you must pay Chervon's usual service and testing costs.
4. Unless otherwise agreed in writing by Chervon, you must pay the cost of transporting the Product to and from Chervon or Chervon's authorised agent and any related insurance cost. Any handling and transportation costs (and other expenses incurred in claiming this warranty) are not covered by this warranty and will not be borne by Chervon.
5. The replacement product or part, or repaired product will be made available for your collection at an address nominated by Chervon.
6. Customers are responsible for the care and cleaning of their product prior to sending it to back to Chervon or its nominated authorised repair agents. Any product being sent for repair must be cleaned. It is an Occupational/Work Health and Safety risk for our staff or authorised repairers to inspect, repair or service a product that has come into contact with a hazardous substance.
7. If Chervon or its authorised repair agent is to inspect, repair or service a product that has come into contact with a hazardous substance such as asbestos, silica dust or other hazardous substance then we may not be able to inspect, service or repair the product. If this is the case, Chervon reserves the right to refuse repair under these circumstances and will inform the customer and the product will be returned at the customer's expense.

EXCLUSIONS

The Warranty does not apply if:

- a) the Product is not supplied in its final shape and form by Chervon or an authorised FLEX Dealer, which can be confirmed on the website store locator (for avoidance of doubt, third party online stores such as eBay, Gumtree, Amazon, etc. are excluded);
- b) the Product is altered, modified or repaired by a party other than Chervon or its agent;
- c) the Product is used other than for its designed purpose;
- d) the Product is used for rental purposes;
- e) the Product is used or installed other than in accordance with Chervon's instructions;
- f) the Product has not been maintained or protected in accordance with Chervon's instructions;
- g) the Product has been subject to abnormal conditions;
- h) the product suffers normal deterioration of the exterior finish, including but not limited to scratches, dents, paint chips, or to any corrosion or discolouring by heat, abrasive and chemical cleaners;
- i) the Product is involved in an accident;
- j) Chervon cannot find any defect in the Product after testing, inspection and assessment;
- k) the alleged defect is due to abuse, misuse, neglect (including failure to clean) or accident;
- l) the alleged defect is due to a failure to properly maintain or use the Product;
- m) the alleged defect in the Product is within acceptable industry standards or tolerances; or
- n) the alleged defect is due to a request to customise the Product;

- o) the alleged defect is due to normal wear and tear, misuse or abuse (including overloading of the product beyond capacity and exposure to water or rain);
- p) The alleged defect has been used or caused due to continuous industrial use.

The Warranty does not extend to:

- a) damage or defects caused by normal wear and tear;
- b) the Products being damaged by you or a third party;
- c) accidental or wilful damage, or misuse; or
- d) theft or vandalism.

This Warranty does not extend to other accessories or attachments.

LIMITATIONS

Chervon makes no express warranties or representations other than as set out in this document. Chervon will not be liable to you or any other person in connection with this Warranty for any:

- a) consequential or indirect loss, damage or costs incurred by you or any other person; or
- b) damage to property, loss of turnover, loss of profits, loss of business or loss of good will.

CONTACT

For Warranty Service or to make a claim please contact Chervon on the details below between the hours of Monday to Friday 9:00am to 5:00pm EST/NZST (as applicable)

Chervon Australia Pty Ltd

Unit 14, 5 Kelletts Rd, Rowville, VIC. 3178.

Ph Australia; 1300 000 346. Email: support@flex-tools.com.au

Chervon New Zealand Subsidiary Ltd

4th Floor, Smith & Caughey Building, 253 Queen St, Auckland, 1141.

Ph New Zealand; 0508 000 346. Email: support@flex-tools.com.au

	NON REGISTER	REGISTRATION WITHIN 30 DAYS OF PURCHASE
PRODUCT OR MODEL #	LIMITED STANDARD WARRANTY PERIOD	LIMITED WARRANTY PERIOD WITH REGISTRATION WITHIN 30 DAYS FROM DATE OF PURCHASE*
FLEX 24V Lithium-ion power tools	3 Years	5 Years
FLEX 24V Lithium-ion Batteries and Chargers	3 Years	5 Years
FLEX Accessories & Consumables	90 Days	90 Days
FLEX STACK PACK™ Storage system	1 Year	1 Year

*Original purchaser must register the product(s) within 30 days of purchase and retain their receipt as proof of purchase. This warranty applies only to the original purchaser from an authorised FLEX dealer and may not be transferred. If original purchaser does not register their product within

30 days, the warranty will apply for the duration set out in table above in column 'LIMITED STANDARD WARRANTY PERIOD'. For avoidance of doubt please refer to warranty table above and full warranty details in this manual or on our website at www.flex-tools.com.au

