

FLEX

POLISHER

PXE 80 10.8-EC

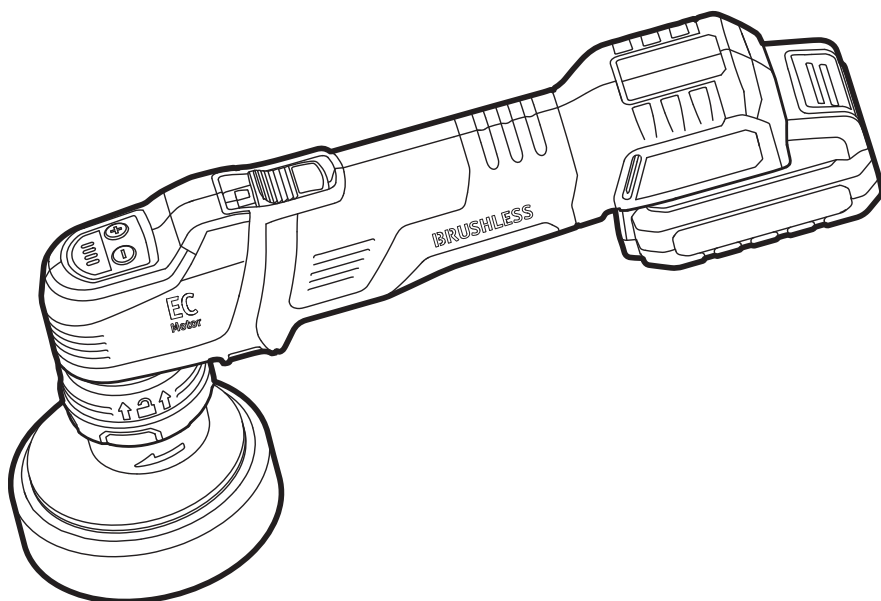

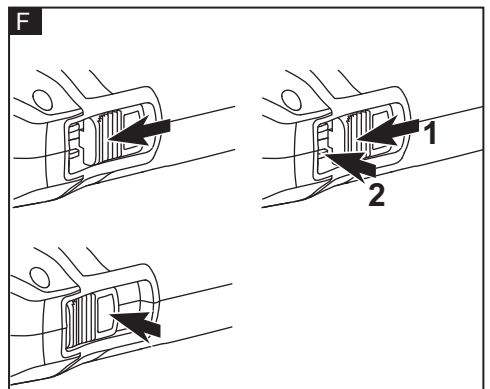
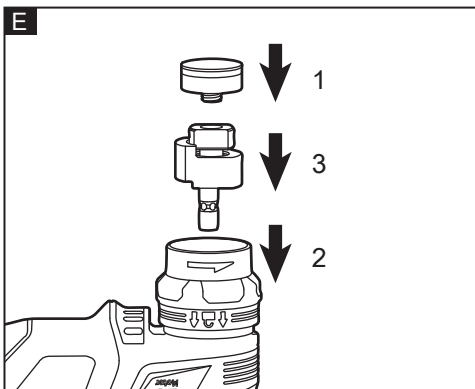
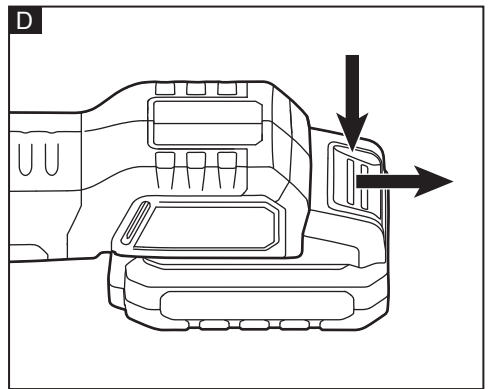
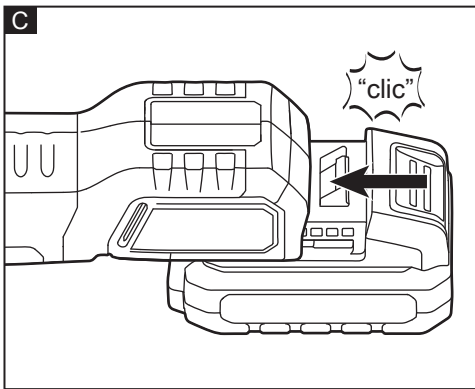
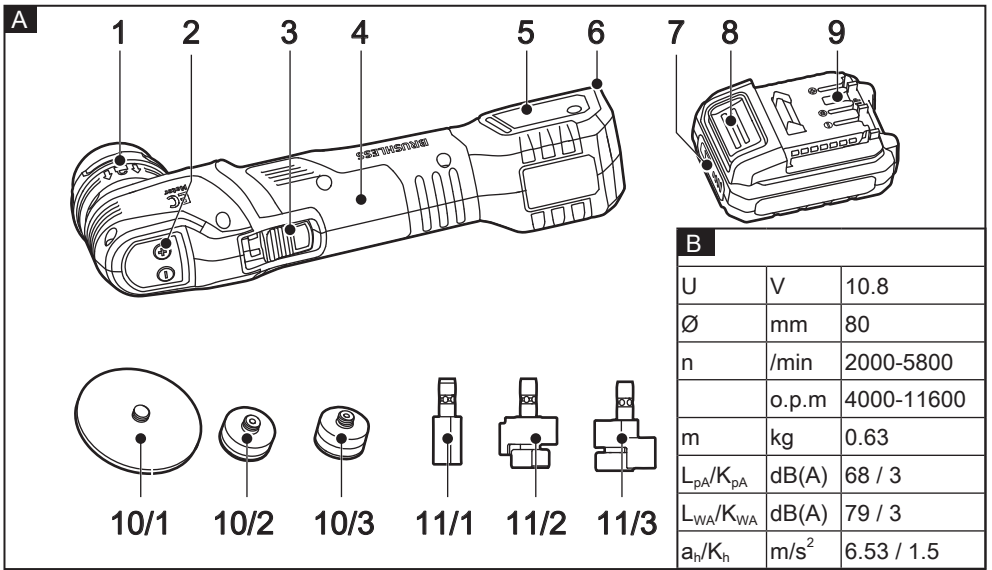

Symbols used in this manual



WARNING!

Denotes impending danger. Non-observance of this warning may result in death or extremely severe injuries.



CAUTION!

Denotes a possibly dangerous situation. Non-observance of this warning may result in slight injury or damage to property.



NOTE

Denotes application tips and important information.

Symbols on the power tool

V volts

/min Rotation rate



To reduce the risk of injury, read the operating instructions!



Disposal information for the old machine (see page 14)!

For your safety



WARNING!

Before using the power tool, please read and follow:

- these operating instructions,
- the “General safety instructions” on the handling of power tools in the enclosed booklet (leaflet-no.: 315.915),
- the currently valid site rules and the regulations for the prevention of accidents.

This power tool is state of the art and has been constructed in accordance with the acknowledged safety regulations.

Nevertheless, when in use, the power tool may be a danger to life and limb of the user or a third party, or the power tool or other property may be damaged.

The polisher may be used only

- as intended,
- in perfect working order.

Faults which impair safety must be repaired immediately.

Intended use

The polisher is designed

- for commercial use in industry and trade,
- for all types of polishing work with polishing sponges, lambskins and woolskins, felt plate, buffing disc,
- for use with polishing tools which are permitted to run at a speed of at least 5800 r.p.m

Safety instructions for polishing



WARNING!

Read all safety warnings, instructions, illustrations and specifications provided with this power tool. Failure to follow all instructions listed below may result in electric shock, fire and/or serious injury. **Save all warnings and instructions for future reference.**

- **This power tool is intended to function as a polisher. Read all safety warnings, instructions, illustrations and specifications provided with this power tool.** Failure to follow all instructions listed below may result in electric shock, fire and/or serious injury.
- **Operations such as grinding, sanding, wire brushing, or cutting-off are not recommended to be performed with this power tool.** Operations for which the power tool was not designed may create a hazard and cause personal injury.
- **Do not use accessories which are not specifically designed and recommended by the tool manufacturer.** Just because the accessory can be attached to your power tool, it does not assure safe operation.
- **The rated speed of the accessory must be at least equal to the maximum speed marked on the power tool.** Accessories running faster than their rated speed can break and fly apart.
- **The outside diameter and the thickness of your accessory must be within the capacity rating of your power tool.** Incorrectly sized accessories cannot be adequately guarded or controlled.
- **Threaded mounting of accessories must match the grinder spindle thread. For accessories mounted by flanges, the arbour hole of the accessory must fit the locating diameter of the flange.** Accessories that do not match the mounting hardware of the power tool will run out of balance, vibrate excessively and may cause loss of control.

- **Do not use a damaged accessory. Before each use inspect the accessory such as abrasive wheels for chips and cracks, backing pad for cracks, tear or excess wear, wire brush for loose or cracked wires. If power tool or accessory is dropped, inspect for damage or install an undamaged accessory. After inspecting and installing an accessory, position yourself and bystanders away from the plane of the rotating accessory and run the power tool at maximum no-load speed for one minute.** Damaged accessories will normally break apart during this test time.
 - **Wear personal protective equipment. Depending on application, use face shield, safety goggles or safety glasses. As appropriate, wear dust mask, hearing protectors, gloves and shop apron capable of stopping small abrasive or workpiece fragments.** The eye protection must be capable of stopping flying debris generated by various operations. The dust mask or respirator must be capable of filtering particles generated by your operation. Prolonged exposure to high intensity noise may cause hearing loss.
 - **Keep bystanders a safe distance away from work area. Anyone entering the work area must wear personal protective equipment.** Fragments of workpiece or of a broken accessory may fly away and cause injury beyond immediate area of operation.
 - **Never lay the power tool down until the accessory has come to a complete stop.** The spinning accessory may grab the surface and pull the power tool out of your control.
 - **Do not run the power tool while carrying it at your side.** Accidental contact with the spinning accessory could snag your clothing, pulling the accessory into your body.
 - **Regularly clean the power tool's air vents.** The motor's fan will draw the dust inside the housing and excessive accumulation of powdered metal may cause electrical hazards.
 - **Do not operate the power tool near flammable materials.** Sparks could ignite these materials.
 - **Do not use accessories that require liquid coolants.** Using water or other liquid coolants may result in electrocution or shock.
- or any other accessory. Pinching or snagging causes rapid stalling of the rotating accessory which in turn causes the uncontrolled power tool to be forced in the direction opposite of the accessory's rotation at the point of the binding. For example, if an abrasive wheel is snagged or pinched by the workpiece, the edge of the wheel that is entering into the pinch point can dig into the surface of the material causing the wheel to climb out or kick out. The wheel may either jump toward or away from the operator, depending on direction of the wheel's movement at the point of pinching. Abrasive wheels may also break under these conditions. Kickback is the result of power tool misuse and/or incorrect operating procedures or conditions and can be avoided by taking proper precautions as given below.
- **Maintain a firm grip on the power tool and position your body and arm to allow you to resist kickback forces. Always use auxiliary handle, if provided, for maximum control over kickback or torque reaction during start-up.** The operator can control torque reactions or kickback forces, if proper precautions are taken.
 - **Never place your hand near the rotating accessory.** Accessory may kickback over your hand.
 - **Do not position your body in the area where power tool will move if kickback occurs.** Kickback will propel the tool in direction opposite to the wheel's movement at the point of snagging.
 - **Use special care when working corners, sharp edges etc. Avoid bouncing and snagging the accessory.** Corners, sharp edges or bouncing have a tendency to snag the rotating accessory and cause loss of control or kickback.

Safety Warnings Specific for Polishing Operations:

- **Do not allow any loose portion of the polishing bonnet or its attachment strings to spin freely. Tuck away or trim any loose attachment strings.** Loose and spinning attachment strings can entangle your fingers or snag on the workpiece.

Kickback and Related Warnings:

Kickback is a sudden reaction to a pinched or snagged rotating wheel, backing pad, brush

Noise and vibration

The noise and vibration values have been determined in accordance with EN 62841. The A evaluated noise level of the power tool is typically:

- Sound pressure level L_{pA} : 68 dB(A);
- Sound power level L_{WA} : 79 dB(A);
- Uncertainty: K = 3.0 dB.

Total vibration value (when polishing painted surfaces):

- Emission value a_h : 6.53 m/s²
- Uncertainty: K = 1.5 m/s²



CAUTION!

The indicated measurements refer to new power tools. Daily use causes the noise and vibration values to change.



NOTE

The vibration emission level given in this information sheet has been measured in accordance with a standardised test given in EN 62841 and may be used to compare one tool with another.

It may be used for a preliminary assessment of exposure. The declared vibration emission level represents the main applications of the tool. However if the tool is used for different applications, with different accessories or poorly maintained, the vibration emission may differ. This may significantly increase the exposure level over the total working period. For a precise estimation of the vibration load the times should also be considered during which the power tool is switched off or even running, but not actually in use. This may significantly decrease the exposure level over the total working period. Identify additional safety measures to protect the operator from the effects of vibration such as: maintain the tool and the accessories, keep the hands warm, organisation of work patterns.



CAUTION!

Wear ear protection at a sound pressure above 85 dB(A).

Technical specifications

PXE 80 10.8-EC	Polisher
Battery	AP 10.8/2.5
Weight of battery/kg	0.26

Average battery life (depending on speed, tool diameter, load ...)/min	20
Working Temperature	-10~40°C
Storage Temperature	-40~70°C
Charging Temperature	5~40°C
Charger	CA 10.8/18.0

Other specifications see figure B

Overview (see figure A)

The numbering of the product features refers to the illustration of the machine on the graphics page.

- 1 **Movable shield**
- 2 **Speed control button**
 - +/- function with 4 levels
 - Level 1-3 "Polishing", Level 4 "spot sanding"
- 3 **Switch**
Switches the power tool on and off and also accelerates it up to the preselected speed.
- 4 **Gear head with handle cover**
With air outlet and direction-of-rotation arrow.
- 5 **Rating plate**
- 6 **Slot for battery**
- 7 **State of charge indicator**
- 8 **Release button for battery**
- 9 **Li-ion battery (2.5 Ah)**
- 10 **Backing plate**
 - 10/1 = polishing and sanding (velcro) backing plat Ø75mm, can be combined with drive types 11/2 and 11/3
 - 10/2 = polishing and sanding (velcro) backing plat Ø35mm, can be combined with all types of drive.
 - 10/3 = sanding backing plat Ø35mm for (glue) spot sanding pads, can be combined with all types of drive.
- 11 **Drive types**
 - 11/1 = rotary drive type, for polishing and sanding, can not be combined with the backing plate Ø75mm (10/1).

- 11/2 = random orbital with 3mm stroke for polishing and sanding, can be combined with all backing plates
- 11/3 = random orbital with 12mm stroke for polishing, can be combined with all backing plates

*Accessories shown or described are not part of the standard delivery scope of the product.

Operating instructions

WARNING!

Remove the battery before carrying out any work on the power tool.

Before switching on the power tool

Unpack the polisher and check that there are no missing or damaged parts.

NOTE

The batteries are not fully charged on delivery. Prior to initial operation, charge the batteries fully. Refer to the charger operating manual.

Inserting/replacing the battery

- Press the charged battery 8 into the power tool until it clicks into place. (see figure C)
- To remove, press the release button 7 and pull out the battery. (see figure D)

CAUTION!

When the device is not in use, protect the battery contacts. Loose metal parts may short-circuit the contacts; explosion and fire hazard!

Battery state of charge

- Press the button to check the state of charge at the state of charge indicator LEDs 7.

The indicator goes out after 5 seconds. If one of the LEDs flashes, the battery must be recharged. If none of the LEDs light up after the button is pressed, the battery is faulty and must be replaced.

Attaching tool holder (see figure E)

- Threaded mounting the backing plate 10 to the driver types 11.
- Push down the movable shield 1.
- Insert the driver types 11 onto the hole of the spindle.
- Release the shield.

Changing tool holder

- Push down the movable shield 1.
- Remove the driver types 11 from the hole of the spindle.

- Insert new driver types
- Release the ring.

Attaching the tools

CAUTION!

Attach tools centrally on tool holder. Imbalances may damage the power tool. The work result may be impaired.

NOTE

Use original FLEX accessories on this model. Not using original FLEX accessories may lead to a poor polishing result, increased vibrations and also greater wear or even damage to the power tool.

Information concerning foam wear

NOTE

In general, foam wear is much higher in connection with free-wheeling eccentric polishing than with rotational polishing or force-driven eccentric polishing.

Due to the drive, this wear does not take place on the outside of the foam but at the foam core instead. The harder/longer the cell structure is subjected to strain and damaged as a result, the faster the build-up of heat. Subsequent damage is inevitable. Wear of this kind cannot be seen on the foam externally. The only reliable action is replacement and disposal in good time to prevent thermal damage to the power tool.

Switching on and off (see figure F)

Brief operation without engaged switch rocker

- Push the switch rocker 3 forwards and engage by pressing the front end.
- To switch off the power tool, release the switch rocker by pressing the rear end.

Preselecting the speed

- To set the operating speed, press the speed control button 2. Selected speed is maintained even when switching off. With the exception of level 4, this always goes back to level 3 after switching off (safety).
- Gently press the switch to accelerate the power tool up to the preselected speed.

CAUTION!

Risk of injury due to destruction of the tool. Use the appropriate tool for the job.

NOTE

In the event of overload or overheating in non-stop operation, the power tool will switch off.

To continue working, switch the power tool off and back on again.



NOTE

When the power tool is switched off, the tool continues running briefly.

If using a polishing paste, use the respective tool for each paste.

Sponges can be washed in the washing machine.

For further information on the manufacturer's products go to www.flex-tools.com.

Maintenance and care



WARNING!

Remove the battery before carrying out any work on the power tool.

Cleaning

- Clean the power tool and grille in front of the vent slots regularly. Frequency of cleaning is dependent on the material and duration of use.
- Regularly blow out the housing interior and motor with dry compressed air.

Spare parts and accessories

For other accessories, in particular tools and polishing aids, see the manufacturer's catalogues.

Exploded drawings and spare-part lists can be found on our homepage:

www.flex-tools.com

Disposal information



WARNING!

Render redundant power tools unusable:

- mains operated power tool by removing the power cord,
- battery operated power tool by removing the battery.



EU countries only

Do not throw electric power tools into the household waste!

In accordance with the European Directive 2012/19/EU on Waste Electrical and Electronic Equipment and transposition into national law used electric power tools must be collected separately and recycled in an environmentally friendly manner.



Raw material recovery instead of waste disposal.

Device, accessories and packaging should be recycled in an environmentally friendly manner. Plastic parts are identified for recycling according to material type.



WARNING!

Do not throw batteries into the household waste, fire or water. Do not open used batteries.

EU countries only:

In accordance with Directive 2006/66/EC defective or used batteries must be recycled.



NOTE

Please ask your dealer about disposal options!

Exemption from liability

The manufacturer and his representative are not liable for any damage and lost profit due to interruption in business caused by the product or by an unusable product. The manufacturer and his representative are not liable for any damage which was caused by improper use of the power tool or by use of the power tool with products from other manufacturers.

FLEX WARRANTY POLICY

For warranty service, please contact FLEX customer service on Australia 1300 000 346 or New Zealand 0508 000 346.

Chervon Australia Pty Ltd ABN 36 165 077 501 and Chervon New Zealand Subsidiary Ltd NZBN 9429049277616 ("Chervon") warrants to the original domestic purchaser that this product will be free from defects in materials and workmanship for 2 years from date of purchase and an additional 1 Year (For a total of 3 Years) with registration via www.flex-tools.com.au or www.flex-tools.co.nz within 30 days of the original purchase. To make a claim, return the faulty item together with proof of purchase directly to your closest service agent or to the place of purchase. Any handling and transportation costs (and other expenses incurred in claiming this warranty) are not covered by this warranty and will not be borne by Chervon. The replacement product or part or repaired product will be made available for your collection at an address nominated by Chervon. Where a valid warranty claim is made, Chervon will replace the defective product or repair the fault. Where the product is repaired, Chervon may use refurbished parts. This warranty does not cover normal wear and tear, misuse, abuse, or continuous industrial use. This warranty only applies to product purchased by you, inside Australia or New Zealand from authorised Australian or New Zealand FLEX dealers. This warranty may also be further limited or voided as specifically detailed in the product Manual. Chervon has no other liability under this warranty. The benefits to you given by this warranty are in addition to other rights and remedies imposed by State and Federal legislation that cannot be excluded. Our goods come with guarantees that cannot be excluded under the Australian Consumer Law and the New Zealand Consumer Guarantee Act 1993. You are entitled to a replacement or refund for a major failure and compensation for any other reasonably foreseeable loss or damage. You are also entitled to have the goods repaired or replaced if the goods fail to be of acceptable quality and the failure does not amount to a major failure. Chervon Australia Pty Ltd, Unit 14, 5 Kelletts Rd, Rowville, VIC 3178.

Chervon New Zealand Subsidiary Ltd, 4th Floor, Smith & Caughey Building, 253 Queen St, Auckland, 1141

Ph: 1300 000 346.

Email: support@flex-tools.com.au

FLEX

Chervon Australia Pty Ltd,
Unit 14, 5 Kelletts Road, Rowville, VIC 3178.

Email: support@flex-tools.com.au

www.flex-tools.com.au

www.flex-tools.co.nz

For all FLEX warranty and enquiries, please contact
Australia 1300 000 346 or New Zealand 0508 000 346



LI-ION BATTERY PACK

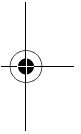
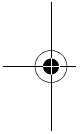

AP 10.8/2.5
AP 18.0/2.5
AP 18.0/5.0

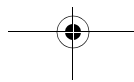

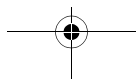
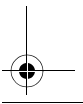
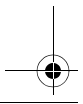
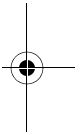
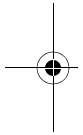
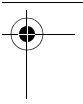
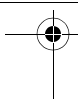

AP 10.8/AP 18.0

Symbols used in this manual



WARNING!

Denotes impending danger.

Non-observance of this warning may result in death or extremely severe injuries.



CAUTION!

Denotes a possibly dangerous situation. Non-observance of this warning may result in slight injury or damage to property.



NOTE

Denotes application tips and important information.

Symbols on the power tool



Before switching on the power tool, read the operating manual!



Protect the battery from heat, e.g. from continuous exposure to sunlight and fire. There is a risk of explosion.



Do not throw battery in the fire. There is a risk of explosion.

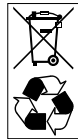

Disposal information (See page 10)!

Safety instructions for Li-ion batteries



WARNING!

Read all safety warnings and all instructions. Failure to follow the warnings and instructions may result in electric shock, fire and/or serious injuries. Save all warnings and instructions for future reference.

- **Do not open the battery.** There is a risk of a short-circuit.
- **Protect the battery from heat, e.g. from continuous exposure to sunlight, fire, water and humidity.** There is a risk of explosion.

en

en

- **If the battery is damaged or used improperly, fumes may be emitted.** Provide fresh air and consult a doctor if you feel unwell. The fumes may irritate the respiratory tract.
- **Under abusive conditions, liquid may be ejected from the battery; avoid contact.** If contact accidentally occurs, flush with water. If liquid contacts eyes, additionally seek medical help. Liquid ejected from the battery may cause irritation or burns.
- **Use only original batteries with the voltage indicated on the rating plate of your electric power tool. If other batteries are used, e.g. imitations, reconditioned batteries or third-party products, there is a risk of injuries as well as damage caused by exploding batteries.**
- **The battery voltage must match the battery charging voltage of the battery charger.** Otherwise there is a risk of fire and explosion.

- **Recharge only with the charger specified by the manufacturer.** A charger that is suitable for one type of battery pack may create a risk of fire when used with another battery pack.
- **Pointed objects, such as nails or screwdrivers, or external forces may damage the battery.** This may cause an internal short-circuit and the battery to burn, smoke, explode or overheat.

Information to ensure a long battery service life



CAUTION!

- *Never charge batteries at temperatures below 0 °C or above 40 °C.*
- *Do not charge batteries in an environment which has high air humidity or at a high ambient temperature.*
- *Do not cover batteries and/or the battery charger during the charging process.*
- *At the end of the charging process pull out the battery charger mains plug.*

AP 10.8/AP 18.0

The battery and battery charger heat up during the charging process. This is normal!

Lithium ion batteries do not exhibit the well known “memory effect”. Nevertheless, before a battery is recharged, it should be fully discharged and the charging process always run to the end.

**NOTE**

- *Follow the instructions for charging the battery in the operating instructions for the electric power tool and the battery charger.*
- *Reduced operating times after recharging indicates that the battery is worn out. The battery must be replaced.*

If the batteries are not used for a prolonged period, store batteries partially charged and in a cool location.

en

Transport

The equivalent lithium content of the batteries included in the product package is below the appropriate limit values. Therefore the battery as an individual component as well as the power tool and its product package are not subject to national or international dangerous goods regulations.

If several machines with lithium ion batteries are transported, these regulations may become relevant and special safety measures may be required (e.g. for the packaging).

In this case find out about the currently valid regulations for the country of use.

**CAUTION!**

Do not post batteries which have a damaged casing.

en

Disposal information



Recycling raw materials instead of waste disposal.

Device, accessories and packaging should be recycled in an environmentally friendly manner. Plastic parts are identified for recycling according to material type.



WARNING!

*Do not throw accumulators/batteries into the household waste, fire or water.
Do not open disused batteries.*

Accumulators/batteries should be collected, recycled or disposed of in an environmentally friendly manner.

i NOTE

Please ask your dealer about disposal options!

AP 10.8/AP 18.0

en

FLEX WARRANTY POLICY

For warranty service, please contact FLEX customer service on Australia 1300 000 346 or New Zealand 0508 000 346.

Chervon Australia Pty Ltd ABN 36 165 077 501 and Chervon New Zealand Subsidiary Ltd NZBN 9429049277616 ("Chervon") warrants to the original domestic purchaser that this product will be free from defects in materials and workmanship for 2 years from date of purchase and an additional 1 Year (For a total of 3 Years) with registration via www.flex-tools.com.au or

www.flex-tools.co.nz within 30 days of the original purchase. To make a claim, return the faulty item together with proof of purchase directly to your closest service agent or to the place of purchase. Any handling and transportation costs (and other expenses incurred in claiming this warranty) are not covered by this warranty and will not be borne by Chervon. The replacement product or part or repaired product will be made available for your collection at an address nominated by Chervon. Where a valid warranty claim is made, Chervon will replace the defective product or repair the fault. Where the product is repaired, Chervon may use refurbished parts.

This warranty does not cover normal wear and tear, misuse, abuse, or continuous industrial use. This warranty only applies to product purchased by you, inside Australia or New Zealand from authorised Australian or New Zealand FLEX dealers. This warranty may also be further limited or voided as specifically detailed in the product Manual. Chervon has no other liability under this warranty. The benefits to you given by this warranty are in addition to other rights and remedies imposed by State and Federal legislation that cannot be excluded. Our goods come with guarantees that cannot be excluded under the Australian Consumer Law and the New Zealand Consumer Guarantee Act 1993. You are entitled to a replacement or refund for a major failure and compensation for any other reasonably foreseeable loss or damage. You are also entitled to have the goods repaired or replaced if the goods fail to be of acceptable quality and the failure does not amount to a major failure. Chervon Australia Pty Ltd, Unit 14, 5 Kelletts Rd, Rowville, VIC. 3178. Chervon New Zealand Subsidiary Ltd, 4th Floor, Smith & Caughey Building, 253 Queen St, Auckland, 1141 Ph: 1300 000 346. Email: support@flex-tools.com.au

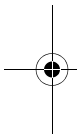

Chervon Australia Pty Ltd,
Unit 14, 5 Kelletts Road, Rowville, VIC. 3178.

Email: support@flex-tools.com.au

www.flex-tools.com.au
www.flex-tools.co.nz

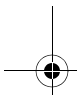
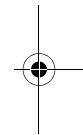

For all FLEX warranty and enquiries, please contact Australia 1300 000 346 or
New Zealand 0508 000 346

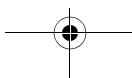
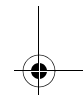

FLEX

BATTERY CHARGER

CA 10.8/18.0

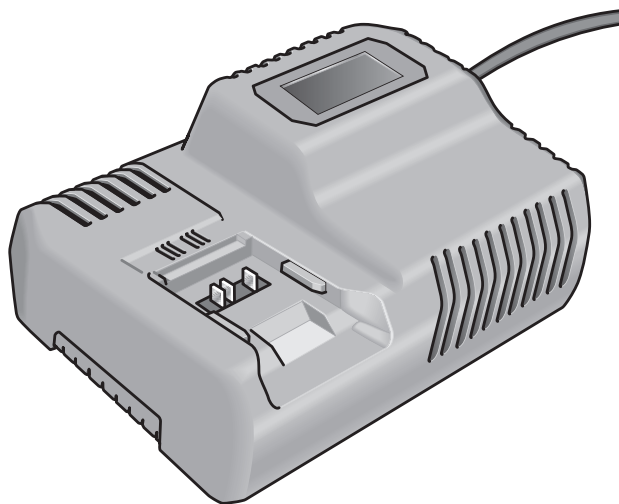

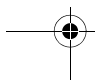
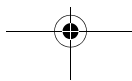
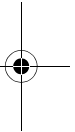
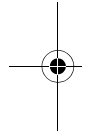
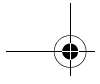

Contents

Symbols used in this manual	3
Symbols on the power tool	3
For your safety	3
Overview	4
Technical specifications	4
Instructions for use	5
Maintenance and care	6
CE-Declaration of Conformity	6
Disposal information	6
Exemption from liability	6

Symbols used in this manual

WARNING!

Denotes impending danger.
Non-observance of this warning may result in death or extremely severe injuries.

CAUTION!

Denotes a possibly dangerous situation.
Non-observance of this warning may result in slight injury or damage to property.

NOTE

Denotes application tips and important information.

Symbols on the power tool



Before switching on the power tool, read the operating manual!



Short-circuit-proof safety transformer



Device is suitable for use indoors only. Do not expose the device to rain. Store electric power tool and batteries in dry rooms.



Disposal information
(See page 10)!

For your safety

WARNING!

Read all safety warnings and all instructions. Failure to follow the warnings and instructions may result in electric shock, fire and/or serious injuries. **Save all warnings and instructions for future reference.**

Before using the battery charger, read and follow:

- these operating instructions,
- the "General safety instructions" on the handling of power tools in the enclosed booklet (leaflet-no.: 315.915),
- the currently valid site rules and the regulations for the prevention of accidents.

This charger is not intended for use by children and persons with physical, sensory or mental limitations or a lack of experience or knowledge.

This charger can be used by children aged 8 or older and by persons who have physical, sensory or mental limitations or a lack of experience or knowledge if they have been supervised or instructed in the safe operation of the charger and understand the associated dangers. Otherwise, there is a danger of operating errors and injuries.

Supervise children. This will ensure that children do not play with the charger.

Cleaning and user maintenance of the battery charger shall not be made by children without supervision.

Intended use

The battery charger CA 10.8/18.0 is designed for charging FLEX batteries of types

- AP 10.8 (2.5 Ah),
- AP 10.8 (4.0 Ah),
- AP 10.8 (6.0 Ah),
- AP 18.0 (2.5 Ah) and
- AP 18.0 (5.0 Ah).

The battery voltage must match the battery charging voltage of the charger. Otherwise there is danger of fire and explosion.

Safety instructions for the battery charger

- **Keep the battery charger away from rain or moisture.** Penetration of water in the battery charger increases the risk of an electric shock.
- **Keep the battery charger clean.** Contamination can lead to danger of an electric shock.
- **Before each use, check the battery charger, cable and plug.** If damage is detected, do not use the battery charger. **Never open the battery charger yourself. Have repairs performed only by a qualified technician and only using original spare parts.** Damaged battery chargers, cables and plugs increase the risk of an electric shock.
- **In case of damage and improper use of the battery, vapours may be emitted.** Ventilate the area and seek medical help in case of complaints. The vapours can irritate the respiratory system.
- **Do not place any objects on the battery charger and do not place the battery charger on soft surfaces.** There is a risk of fire.
- **Always check that the mains voltage matches the voltage indicated on the rating plate of the battery charger.**

Overview

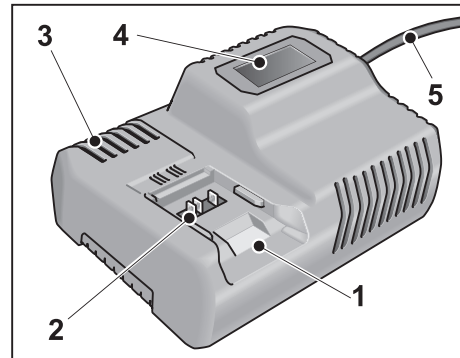

- 1 Slot for battery
- 2 Contacts
- 3 Ventilation slots
- 4 Display for indicating the operating status
- 5 Power cord with plug

Technical specifications

Device	Battery charger CA 10.8/18.0	
Input voltage	V~/Hz	220-240/ 50-60
Charging voltage	V-	12/20
Charging time (depending on charge state)		
	AP 10.8/2.5 min	40
	AP 10.8/4.0 min	40
	AP 10.8/6.0 min	55
	AP 18.0/2.5 min	40
	AP 18.0/5.0 min	45
Operating temperature	°C	5-40
Weight (without battery)	kg	0.89
Protection class	II / □	

Instructions for use

CAUTION!

- Never charge batteries at temperatures below 5 °C or above 40 °C.
- Do not charge batteries in an environment which has high air humidity or at a high ambient temperature.
- Do not cover batteries and/or the battery charger during the charging process.
- At the end of the charging process pull out the battery charger mains plug.

Charging process

CAUTION!

Use only original batteries in the supplied battery charger.

- Insert the mains plug of the battery charger.
The backlighting of the display is lit green for 2 seconds and then goes out. OK is displayed.

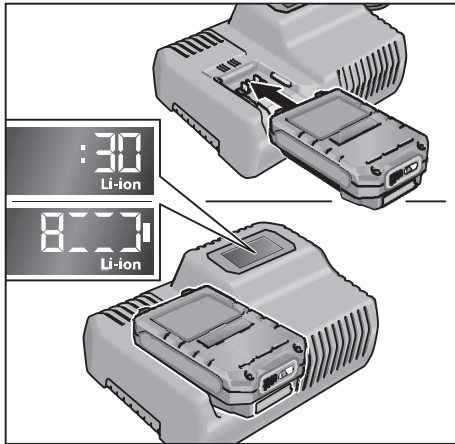

- Insert battery fully into the battery charger.
 - The display indicates alternately the remaining duration of the charging process (until the battery is fully charged) and a graphical representation of the charging state.

- The backlighting of the display is lit orange when the battery is less than 80% charged.
- From a battery charge of 80% the display is lit green and OK is displayed.

- The battery is fully charged when the display  appears.

The green backlighting goes out after a short time.

- Take the battery out of the battery charger.

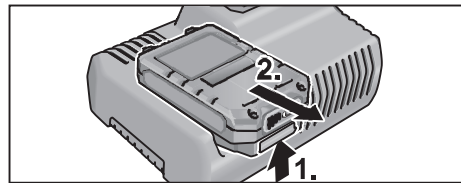

- Pull out the mains plug.

NOTE

If the display flashes after the battery has been inserted into the battery charger, the battery or battery charger is defective.

 Display flashes slowly.
Backlighting orange.

The battery is too hot or too cold. When the battery has reached the charging temperature (5°C–40°C), the charging process starts.

 Display flashes rapidly.
Backlighting red.

Take the battery out of the battery charger and re-insert. If the display is the same, the battery is defective. Replace battery or have it tested at a service centre.

If this error message is also displayed with a different battery, the battery charger is defective. Have the battery charger tested at a service centre.

Maintenance and care

WARNING!

Before performing any work, pull out the mains plug. Do not use water or liquid detergents.

- Remove dirt and dust from the housing with a paint brush or dry cloth.

Repairs

Repairs may be carried out by an authorised customer service centre only.

Exploded drawings and spare-part lists can be found on our homepage:

www.flex-tools.com.au

Disposal information

WARNING!

Render redundant power tools unusable by removing the power cord.

Recycling raw materials instead of waste disposal.

Device, accessories and packaging should be recycled in an environmentally friendly manner. Plastic parts are identified for recycling according to material type.

WARNING!

*Do not throw accumulators/batteries into the household waste, fire or water.
Do not open disused batteries.*

Accumulators/batteries should be collected, recycled or disposed of in an environmentally friendly manner.

NOTE

Please ask your dealer about disposal options!

Exemption from liability

The manufacturer and his representative are not liable for any damage and lost profit due to interruption in business caused by the product or by an unusable product.

The manufacturer and his representative are not liable for any damage which was caused by improper use of the power tool or by use of the power tool with products from other manufacturers.

FLEX WARRANTY POLICY

For warranty service, please contact FLEX customer service on Australia 1300 000 346 or New Zealand 0508 000 346. Chervon Australia Pty Ltd ABN 36 165 077 501 and Chervon New Zealand Subsidiary Ltd NZBN 9429049277616 ("Chervon") warrants to the original domestic purchaser that this product will be free from defects in materials and workmanship for 2 years from date of purchase and an additional 1 Year (For a total of 3 Years) with registration via www.flex-tools.com.au or www.flex-tools.co.nz within 30 days of the original purchase. To make a claim, return the faulty item together with proof of purchase directly to your closest service agent or to the place of purchase. Any handling and transportation costs (and other expenses incurred in claiming this warranty) are not covered by this warranty and will not be borne by Chervon. The replacement product or part or repaired product will be made available for your collection at an address nominated by Chervon. Where a valid warranty claim is made, Chervon will replace the defective product or repair the fault. Where the product is repaired, Chervon may use refurbished parts. This

warranty does not cover normal wear and tear, misuse, abuse, or continuous industrial use. This warranty only applies to product purchased by you, inside Australia or New Zealand from authorised Australian or New Zealand FLEX dealers. This warranty may also be further limited or voided as specifically detailed in the product Manual. Chervon has no other liability under this warranty. The benefits to you given by this warranty are in addition to other rights and remedies imposed by State and Federal legislation that cannot be excluded. Our goods come with guarantees that cannot be excluded under the Australian Consumer Law and the New Zealand Consumer Guarantee Act 1993. You are entitled to a replacement or refund for a major failure and compensation for any other reasonably foreseeable loss or damage. You are also entitled to have the goods repaired or replaced if the goods fail to be of acceptable quality and the failure does not amount to a major failure. Chervon Australia Pty Ltd, Unit 14, 5 Kelletts Rd, Rowville, VIC. 3178. Chervon New Zealand Subsidiary Ltd, 4th Floor, Smith & Caughey Building, 253 Queen St, Auckland, 1141 Ph: 1300 000 346. Email: support@flex-tools.com.au

FLEX

Chervon Australia Pty Ltd,
Unit 14, 5 Kelletts Road, Rowville, VIC. 3178.

Email: support@flex-tools.com.au

www.flex-tools.com.au
www.flex-tools.co.nz

For all FLEX warranty and enquiries, please contact Australia 1300 000 346 or
New Zealand 0508 000 346