

FLEX

OPERATOR'S MANUAL

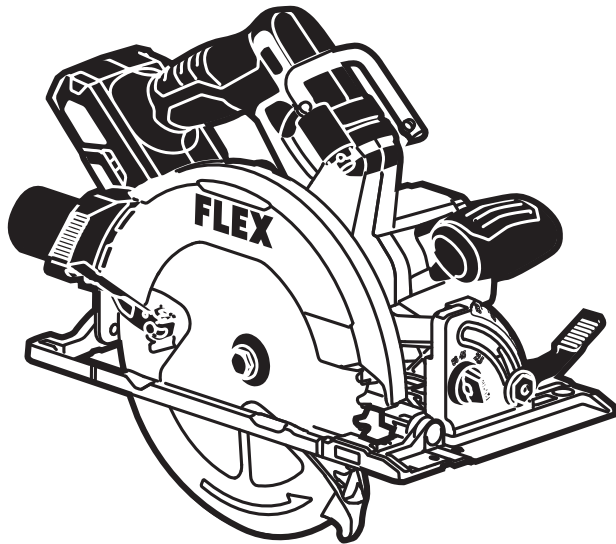

Model: FXA2141

24V BRUSHLESS CIRCULAR SAW

⚠ WARNING: To reduce the risk of injury, the user must read and understand the Operator's Manual before using this product. Save these instructions for future reference.







Please contact FLEX customer service in Australia 1300 000 346 or New Zealand 0508 000 346 any time you have questions or warranty claims.

SAFETY SYMBOLS

The purpose of safety symbols is to attract your attention to possible dangers. The safety symbols and the explanations with them deserve your careful attention and understanding. The symbol warnings do not, by themselves, eliminate any danger. The instructions and warnings they give are no substitutes for proper accident prevention measures.

⚠ WARNING Be sure to read and understand all safety instructions in this Operator's Manual, including all safety alert symbols such as "**DANGER**", "**WARNING**" and "**CAUTION**" before using this tool. Failure to follow all instructions listed below may result in electric shock, fire, and/or serious personal injury.

The definitions below describe the level of severity for each signal word. Please read the manual and pay attention to these symbols.	
	This is the safety alert symbol. It is used to alert you to potential personal injury hazards. Obey all safety messages that follow this symbol to avoid possible injury or death.
	DANGER indicates a hazardous situation which, if not avoided, will result in death or serious injury.
	WARNING indicates a hazardous situation which, if not avoided, could result in death or serious injury.
	CAUTION, used with the safety alert symbol, indicates a hazardous situation which, if not avoided, will result in minor or moderate injury.

GENERAL POWER TOOL SAFETY WARNINGS



WARNING Read all safety warnings, instructions, illustrations and specifications provided with this power tool. Failure to follow all instructions listed below may result in electric shock, fire and/or serious injury.

SAVE ALL WARNINGS AND INSTRUCTIONS FOR FUTURE REFERENCE.

The term “power tool” in the warnings refers to your mains-operated (corded) power tool or battery-operated (cordless) power tool.

Work area safety

Keep work area clean and well lit. Cluttered or dark areas invite accidents.

Do not operate power tools in explosive atmospheres, such as in the presence of flammable liquids, gases or dust. Power tools create sparks which may ignite the dust or fumes.

Keep children and bystanders away while operating a power tool. Distractions can cause you to lose control.

Electrical safety

Power tool plugs must match the outlet. Never modify the plug in any way. Do not use any adaptor plugs with earthed (grounded) power tools. Unmodified plugs and matching outlets will reduce risk of electric shock.

Avoid body contact with earthed or grounded surfaces, such as pipes, radiators, ranges and refrigerators. There is an increased risk of electric shock if your body is earthed or grounded.

Do not expose power tools to rain or wet conditions. Water entering a power tool will increase the risk of electric shock.

Do not abuse the cord. Never use the cord for carrying, pulling or unplugging the power tool. Keep cord away from heat, oil, sharp edges or moving parts. Damaged or entangled cords increase the risk of electric shock.

When operating a power tool outdoors, use an extension cord suitable for outdoor use. Use of a cord suitable for outdoor use reduces the risk of electric shock.

If operating a power tool in a damp location is unavoidable, use a residual current device (RCD) protected supply. Use of an RCD reduces the risk of electric shock.

Personal safety

Stay alert, watch what you are doing and use common sense when operating a power tool. Do not use a power tool while you are tired or under the influence of drugs, alcohol or medication. A moment of inattention while operating power tools may result in serious personal injury.

Use personal protective equipment. Always wear eye protection. Protective equipment such as a dust mask, non-skid safety shoes, hard hat or hearing protection used for appropriate conditions will reduce personal injuries.

Prevent unintentional starting. Ensure the switch is in the off-position before connecting to power source and/or battery pack, picking up or carrying the tool. Carrying power tools with your finger on the switch or energising power tools that have the switch on invites accidents.

Remove any adjusting key or wrench before turning the power tool on. A wrench or a key left attached to a rotating part of the power tool may result in personal injury.

Do not overreach. Keep proper footing and balance at all times. This enables better control of the power tool in unexpected situations.

Dress properly. Do not wear loose clothing or jewelry. Keep your hair and clothing away from moving parts. Loose clothes, jewelry or long hair can be caught in moving parts.

If devices are provided for the connection of dust extraction and collection facilities, ensure these are connected and properly used. Use of dust collection can reduce dust-related hazards.

Do not let familiarity gained from frequent use of tools allow you to become complacent and ignore tool safety principles. A careless action can cause severe injury within a fraction of a second.

Power tool use and care

Do not force the power tool. Use the correct power tool for your application. The correct power tool will do the job better and safer at the rate for which it was designed.

Do not use the power tool if the switch does not turn it on and off. Any power tool that cannot be controlled with the switch is dangerous and must be repaired.

Disconnect the plug from the power source and/or remove the battery pack, if detachable, from the power tool before making any adjustments, changing accessories, or storing power tools. Such preventive safety measures reduce the risk of starting the power tool accidentally.

Store idle power tools out of the reach of children and do not allow persons unfamiliar with the power tool or these instructions to operate the power tool. Power tools are dangerous in the hands of untrained users.

Maintain power tools and accessories. Check for misalignment or binding of moving parts, breakage of parts and any other condition that may affect the power tool's operation. If damaged, have the power tool repaired before use. Many accidents are caused by poorly maintained power tools.

Keep cutting tools sharp and clean. Properly maintained cutting tools with sharp cutting edges are less likely to bind and are easier to control.

Use the power tool, accessories and tool bits etc. in accordance with these instructions, taking into account the working conditions and the work to be performed.

Use of the power tool for operations different from those intended could result in a hazardous situation.

Keep handles and grasping surfaces dry, clean and free from oil and grease. Slippery handles and grasping surfaces do not allow for safe handling and control of the tool in unexpected situations.

Battery tool use and care

Recharge only with the charger specified by the manufacturer. A charger that is suitable for one type of battery pack may create a risk of fire when used with another battery pack.

Use power tools only with specifically designated battery packs. Use of any other battery packs may create a risk of injury and fire.

When battery pack is not in use, keep it away from other metal objects, like paper clips, coins, keys, nails, screws or other small metal objects, that can make a connection from one terminal to another. Shorting the battery terminals together may cause burns or a fire.

Under abusive conditions, liquid may be ejected from the battery; avoid contact. If contact accidentally occurs, flush with water. If liquid contacts eyes, additionally seek medical help. Liquid ejected from the battery may cause irritation or burns.

Do not use a battery pack or tool that is damaged or modified. Damaged or modified batteries may exhibit unpredictable behavior resulting in fire, explosion or risk of injury.

Do not expose a battery pack or tool to fire or excessive temperature. Exposure to fire or temperature above 130 °C may cause explosion.

Follow all charging instructions and do not charge the battery pack or tool outside the temperature range specified in the instructions. Charging improperly or at temperatures outside the specified range may damage the battery and increase the risk of fire.

Service

Have your power tool serviced by a qualified repair person using only identical replacement parts. This will ensure that the safety of the power tool is maintained.

Never service damaged battery packs. Service of battery packs should only be performed by the manufacturer or authorised service providers.

SAFETY INSTRUCTIONS FOR CIRCULAR SAWS

Cutting procedures

⚠ DANGER Keep hands away from cutting area and the blade.

Keep your second hand on auxiliary handle, or motor housing. If both hands are holding the saw, they cannot be cut by the blade.

Do not reach underneath the workpiece. The guard cannot protect you from the blade below the workpiece.

Adjust the cutting depth to the thickness of the workpiece. Less than a full tooth of the blade teeth should be visible below the workpiece.

Never hold the workpiece in your hands or across your leg while cutting. Secure the workpiece to a stable platform. It is important to support the work properly to minimise body exposure, blade binding, or loss of control.

Hold the power tool by insulated gripping surfaces, when performing an operation where the cutting tool may contact hidden wiring. Contact with a “live” wire will also make exposed metal parts of the power tool “live” and could give the operator an electric shock.

When ripping, always use a rip fence or straight edge guide. This improves the accuracy of cut and reduces the chance of blade binding.

Always use blades with correct size and shape (diamond versus round) of arbor holes. Blades that do not match the mounting hardware of the saw will run off-centre, causing loss of control.

Never use damaged or incorrect blade washers or bolt. The blade washers and bolt were specially designed for your saw, for optimum performance and safety of operation.

Kickback causes and related warnings

Kickback is a sudden reaction to a pinched, jammed or misaligned saw blade, causing an uncontrolled saw to lift up and out of the workpiece toward the operator;

When the blade is pinched or jammed tightly by the kerf closing down, the blade stalls and the motor reaction drives the unit rapidly back toward the operator;

If the blade becomes twisted or misaligned in the cut, the teeth at the back edge of the blade

can dig into the top surface of the wood causing the blade to climb out of the kerf and jump back toward the operator.

Kickback is the result of saw misuse and/or incorrect operating procedures or conditions and can be avoided by taking proper precautions as given below.

Maintain a firm grip with both hands on the saw and position your arms to resist kickback forces. Position your body to either side of the blade, but not in line with the blade. Kickback could cause the saw to jump backwards, but kickback forces can be controlled by the operator, if proper precautions are taken.

When blade is binding, or when interrupting a cut for any reason, release the trigger and hold the saw motionless in the material until the blade comes to a complete stop. Never attempt to remove the saw from the work or pull the saw backward while the blade is in motion or kickback may occur. Investigate and take corrective actions to eliminate the cause of blade binding.

When restarting a saw in the workpiece, centre the saw blade in the kerf so that the saw teeth are not engaged into the material. If a saw blade binds, it may walk up or kickback from the workpiece as the saw is restarted.

Support large panels to minimise the risk of blade pinching and kickback. Large panels tend to sag under their own weight. Supports must be placed under the panel on both sides, near the line of cut and near the edge of the panel.

Do not use dull or damaged blades. Unsharpened or improperly set blades produce narrow kerf causing excessive friction, blade binding and kickback.

Blade depth and bevel adjusting locking levers must be tight and secure before making the cut. If blade adjustment shifts while cutting, it may cause binding and kickback.

Use extra caution when sawing into existing walls or other blind areas. The protruding blade may cut objects that can cause kickback.

Lower guard function

Check the lower guard for proper closing before each use. Do not operate the saw if the lower guard does not move freely and close instantly. Never clamp or tie the lower guard into the open position. If the saw is accidentally dropped, the lower guard may be bent. Raise the lower guard with the retracting handle and make sure it moves freely and does not touch the blade or any other part, in all angles and depths of cut.

Check the operation of the lower guard spring. If the guard and the spring are not operating properly, they must be serviced before use. Lower guard may operate sluggishly due to damaged parts, gummy deposits, or a build-up of debris.

The lower guard may be retracted manually only for special cuts such as “plunge cuts” and “compound cuts”. Raise the lower guard by the retracting handle and as soon as the blade enters the material, the lower guard must be released. For all other sawing, the lower guard should operate automatically.

Always observe that the lower guard is covering the blade before placing the saw down on bench or floor. An unprotected, coasting blade will cause the saw to walk backwards, cutting whatever is in its path. Be aware of the time it takes for the blade to stop after switch is released.

Do not run the tool while carrying it at your side. Lower guard may be opened by a contact with your clothing. Accidental contact with the spinning saw blade could result in serious personal injury.

Periodically remove the blade, clean the upper, lower guards with kerosene and wipe it dry, or blow it clean with compressed air. Preventive maintenance and properly operating guard will reduce the probability of an accident.

Use clamps or other practical way to secure and support the workpiece to a stable platform. Holding the work by hand or against your body is unstable and may lead to loss of control.

Inspect the condition and quality of the wood and remove all nails from timber before cutting. Wet timber, green timber or pressure treated timber require special attention during cutting operation to prevent kickback.

Hold the saw firmly to prevent loss of control. Figures in this manual illustrate typical hand support of the saw.









This circular saw should not be mounted to a table and converted to a table saw. Circular saws are not designed or intended to be used as table saws.



Never place your hand behind the saw blade. Kickback could cause the saw to jump backwards over your hand.

Do not use the saw with an excessive depth of cut setting. Too much blade exposure increases the likelihood of the blade twisting in the kerf and increases the surface area of the blade available for pinching that leads to kickback

SYMBOLS

IMPORTANT: Some of the following symbols may be used on your tool. Please study them and learn their meaning. Proper interpretation of these symbols will allow you to operate the tool better and safer.

Symbol	Name	Designation/Explanation
V	Volts	Voltage
A	Amperes	Current
Hz	Hertz	Frequency (cycles per second)
W	Watt	Power
kg	Kilograms	Weight
min	Minutes	Time
s	Seconds	Time
Wh	Watt-hours	Battery capacity
Ah	Ampere-hours	Battery capacity
∅	Diameter	Size of drill bits, grinding wheels, etc.
n_0	No load speed	Rotational speed, at no load
n	Rated speed	Maximum attainable speed
.../min	Revolutions or reciprocations per minute (rpm)	Revolutions, strokes, surface speed, orbits, etc. per minute
O	Off position	Zero speed, zero torque...
1,2,3,... I,II,III,	Selector settings	Speed, torque, or position settings. Higher number means greater speed
	Infinitely variable selector with off	Speed is increasing from 0 setting
	Arrow	Action in the direction of arrow
	Alternating current (AC)	Type or a characteristic of current
	Direct current (DC)	Type or a characteristic of current
	Alternating or direct current (AC / DC)	Type or a characteristic of current
	Class II tool	Designates Double Insulated Construction tools.
	WEEE	Waste electrical products should not be disposed of with household waste. Take to an authorised recycler.
	Read the instructions	Alerts user to read manual

Symbol	Name	Designation/Explanation
 A circular icon with a black border. Inside the circle, a pair of safety glasses is depicted in white against a black background.	Wear eye protection symbol	Alerts user to wear eye protection
 A triangular icon with a black border. Inside the triangle, there is a white checkmark on a black background.	Regulatory compliance mark	This product complies with applicable Australian standards.

FUNCTIONAL DESCRIPTIONS AND SPECIFICATIONS

Circular Saw

Fig. 1a

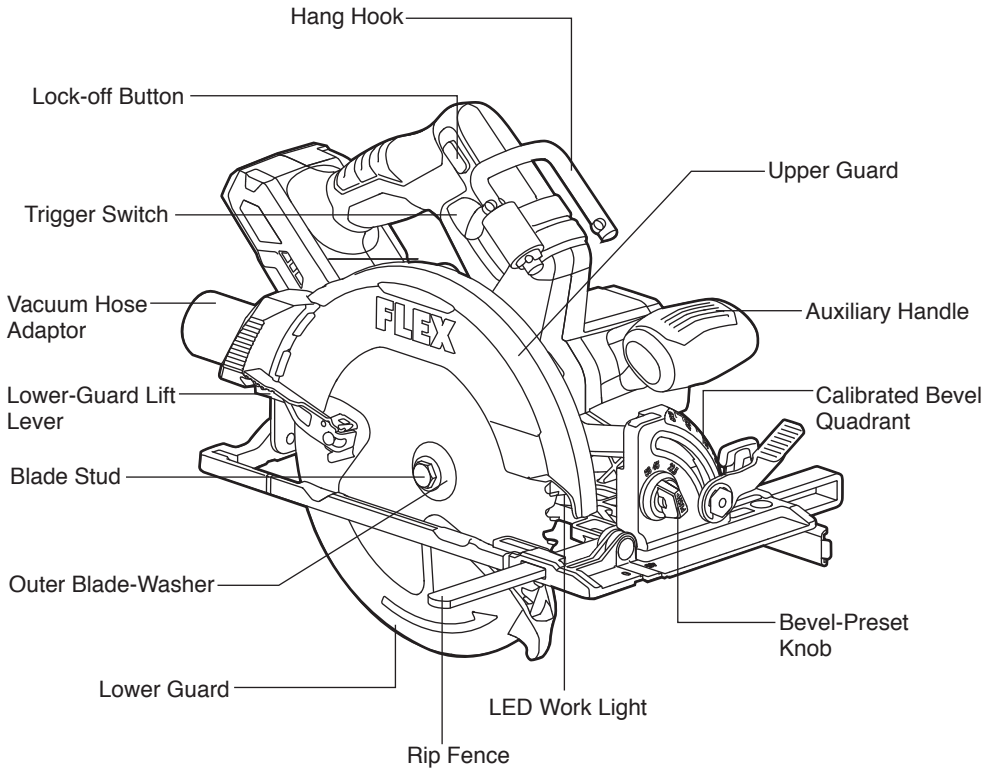
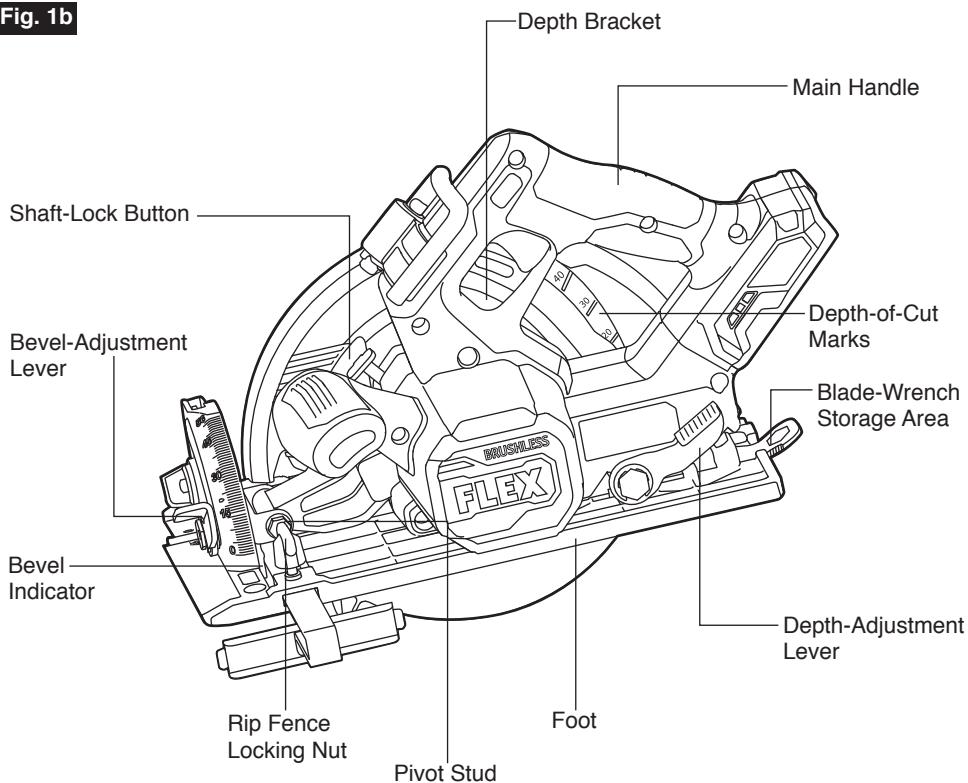

Fig. 1b



Model No.	FXA2141
Rated Voltage	24 V d.c.
No Load Speed	5800 /min
Bevel Capacity	0 – 56°
Blade	Ø 184 mm
Blade Arbor Hole	Ø 20 mm
Depth of cut at 90°	66 mm
Depth of cut at 45°	48 mm
Depth of cut at 56°	38 mm
Recommended operating temperature	-20 – 40°C
Recommended storage temperature	< 50°C

Intended Use

This tool is only designed for wood-cutting; it is not designed for use with metal or masonry cut-off wheels.

⚠ WARNING Do not use abrasive wheels with circular saws. Abrasive dust may cause the lower guard to not operate properly.

ASSEMBLY

⚠ WARNING Detach the battery pack from the tool before making any assembly, adjustments or changing accessories. Such preventive safety measures reduce the risk of starting the tool accidentally.

TO ATTACH/DETACH BATTERY PACK (FIG. 2)

To attach the battery pack:

Align the raised rib on the battery pack with the grooves in the tool, and then slide the battery pack onto the tool.

NOTICE: Make sure that the latch on the battery pack snaps into place and that the battery pack is secured to the tool before beginning operation.

NOTICE: When placing the battery pack onto the tool, be sure that the raised rib on the battery pack aligns with the groove inside the tool and that the latches snap into place properly. Improper attachment of the battery pack can cause damage to internal components.

To detach the battery pack:

Depress the battery-release button located on the front of the battery pack, to release the battery pack. Pull the battery pack out and remove it from the tool.

⚠ WARNING Battery tools are always in operating condition.

Therefore, remove the battery when the tool is not in use or when carrying it at your side.

Fig. 2

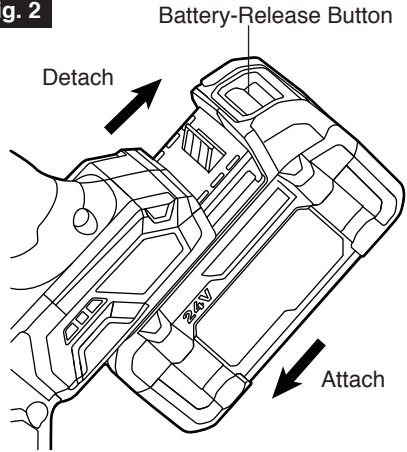

ATTACHING THE BLADE (FIG. 3)

⚠ WARNING Detach the battery pack from the tool before performing any assembly or adjustments or changing accessories. Such preventive safety measures reduce the risk of starting the tool accidentally.

⚠ WARNING Use only Ø184mm saw blades rated 5800/min or greater. NEVER use a blade that is so thick that it prevents the outer blade washer from engaging with the flat side of the spindle. Using a blade not designed for the saw may result in serious personal injury and property damage.

- Take the blade wrench from its storage area.
- Press the shaft-lock button and turn blade wrench until the shaft-lock button engages. The saw shaft is now locked. Continue to depress the shaft-lock button, turn the blade wrench counterclockwise and remove the blade stud and the outer washer.
- Make sure that the saw teeth and the arrow on the blade point in the same direction as the arrow on the lower guard.
- Retract the lower guard all the way up into the upper guard. While retracting the lower guard, check the operation and condition of the lower-guard spring.

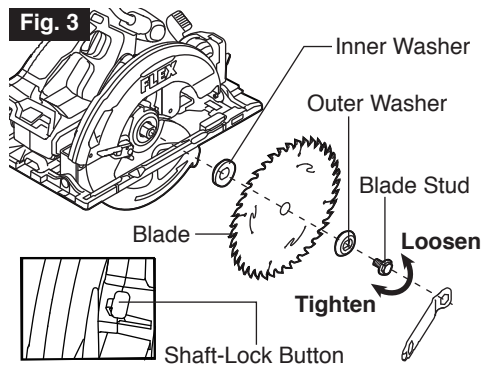

- Slide the blade through the slot in the foot and mount it against the inner washer on the shaft. Be sure that the large diameter of the inner and outer washers lay flush against the blade.
- Reinstall the OUTER WASHER. First finger tighten the blade stud, then tighten the blade stud 1/8 turn (45°) with the blade wrench provided.

NOTICE: Do not use a blade wrench with a longer handle, since it may lead to over tightening of the blade stud.

NOTICE: Always clean the spindle, upper guard, and lower guard to remove any dirt and sawdust.

ATTACHING THE VACUUM HOSE ADAPTOR (FIG. 4)

⚠ WARNING Always wear a dust mask during use.

Align the vacuum hose adaptor with the opening on the upper guard, fix the vacuum hose adaptor in place by using a screw (provided).

To extract the saw dust created during cutting, connect a suitable vacuum cleaner with a Ø32mm suction hose to the vacuum hose adaptor.

Make sure the vacuum hose has freedom to move and has enough length to complete the cut. If needed, have another person move the vacuum cleaner and the hose while you are making the cut.

Before starting a cut, make sure that the airflow through the upper guard is not obstructed.

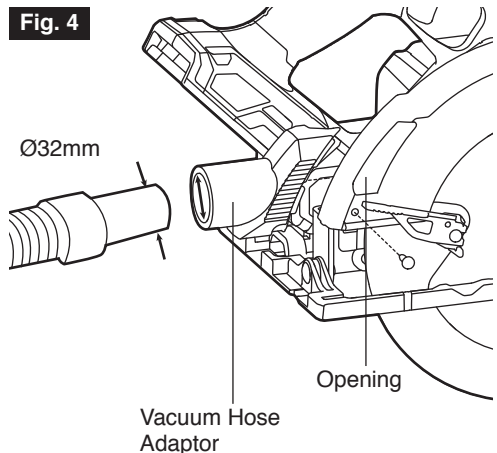

ADJUSTMENTS

DEPTH ADJUSTMENT (FIG. 5A AND 5B)

- Remove the battery pack from the circular saw.
- Loosen the depth-adjustment lever by pushing it up towards the motor housing.
 - Hold the foot down with one hand and use the handle to raise or lower the saw.
 - Align the notch on the depth bracket with the desired depth-of-cut mark on the upper guard and tighten the depth-adjustment lever.

Check the set depth. Not more than one tooth length of the blade should extend below the material to be cut to minimise splintering.

NOTICE: The four most common cutting depths are marked on the upper guard. These settings help the operator to quickly set the saw to cut through the material with thickness of 10mm, 20mm, 30mm and 40mm, respectively, while allowing one tooth length of the blade to extend below the material.

Fig. 5A

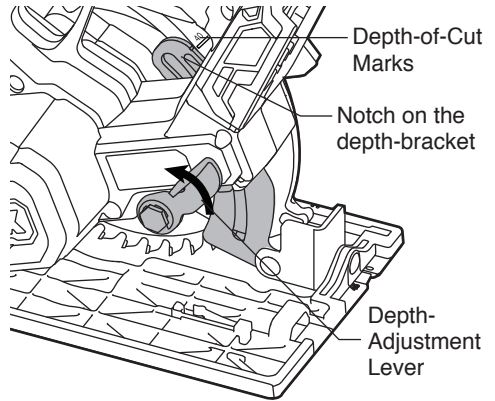
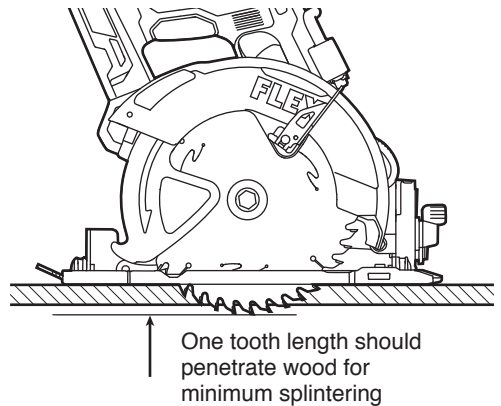

Fig. 5B



CHECK THE 90° CUTTING ANGLE (FIG. 6)

- Remove the battery pack from the circular saw.
- Set the foot to the maximum depth of cut setting. Loosen the bevel-adjustment lever, set the bevel indicator to 0° on quadrant, retighten the lever, and check for 90° angle between the blade and bottom plane of foot with a square.
 - Use a 2.5mm hex key (not included) to make adjustments, if necessary, by turning the small alignment screw from bottom side of the foot.

Fig. 6

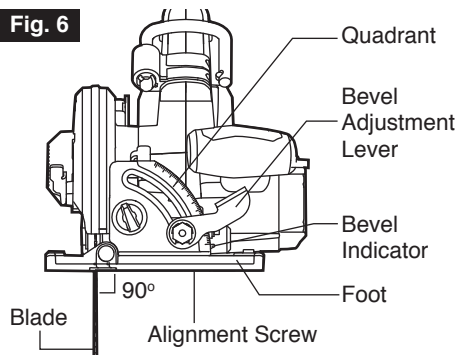

BEVEL ADJUSTMENT (FIG. 7)

Remove the battery pack from the circular saw. Your tool is equipped with a bevel-preset knob and a bevel adjustment lever at the front of the saw, to control bevel angle setting.

NOTICE: The bevel-preset knob of your saw was set to 56° at the factory.

The bevel-preset knob allows the operator to quickly set bevel at 22.5°, 45°, and 56°.

To use the bevel-preset knob

- Push the bevel-preset knob and turn it to one of the desired settings – 22.5°, 45°, or 56°.
- Release the bevel-preset knob and it will serve as a travel stop when adjusting the bevel angle.

To use the bevel-adjustment lever

With the bevel-preset knob set, the operator can quickly set the bevel angle to one of the presets 22.5°, 45°, and 56° or select a desired bevel angle within the selected angle range.

- Loosen the bevel-adjustment lever.
- Tilt the saw as far as possible until it is blocked by the bevel-preset knob at either 22.5°, 45°, or 56°. If a custom bevel angle within the selected angle range (e.g. 22.5 – 45°), tilt the saw until the bevel indicator is aligned with the desired angle mark on the quadrant.
- Tighten the bevel-adjustment lever.

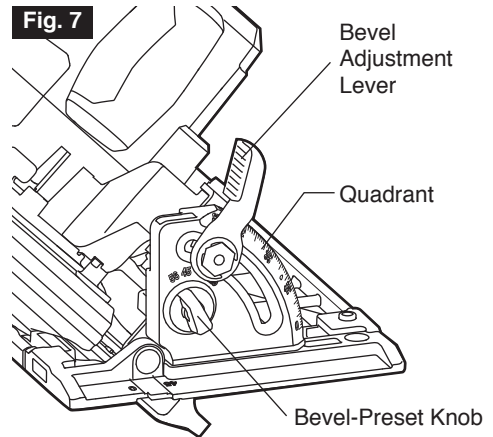

⚠ WARNING Because of the increased amount of blade engagement in the work and decreased stability of the foot, blade binding may occur. Keep the saw steady and the foot firmly on the workpiece.

LINE GUIDE (FIG. 8)

For a 0° cut and a 45° bevel cut, use the respective marks on the foot for guidance. The cutting guide will indicate an approximate line of cut. Make sample cuts in scrap timber to verify the actual line of cut. This will be helpful because of the number of different blade types and thicknesses available. To ensure minimum splintering on the good side of the material to be cut, face the good side down.

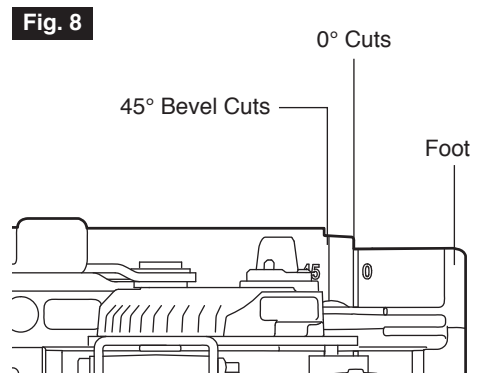

HANG HOOK (FIG. 9)

Your tool is equipped with a hook. Use the hook to hang the saw from a rafter or beam or other similar secure structure for temporary storage during work. Recommended timber size to support the saw with the hook: 70x35mm, 90x35mm.

To use, lift up the hook until it snaps into the open position.

When not in use, always lower the hook until it snaps into the closed position.

⚠ WARNING When the saw is hung by the hook, do not shake the saw or the object that it is hanging from. Do not hang the saw from any electrical wires. Make sure that the structure used to hang the saw is secure. Personal injury or property damage may occur.

Only use the hook for hanging the saw. Using the hook to hang anything else could lead

Fig. 9

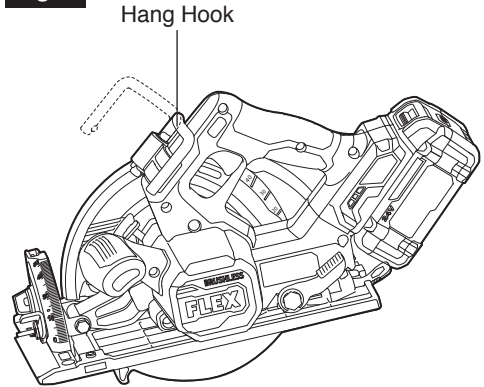

to serious injury.

Do not use the hook to reach another object or use the hook to support your weight in any situation.

OPERATION INSTRUCTIONS

⚠ WARNING To reduce the risk of fire, personal injury, and product damage due to a short circuit, never immerse your tool, battery pack or charger in fluid or allow a fluid to flow inside them. Corrosive or conductive fluids, such as seawater, certain industrial chemicals, and bleach or bleach-containing products, etc. can cause a short circuit.

⚠ WARNING If any parts are damaged or missing, do not operate this product until the parts are replaced. Use of this product with damaged or missing parts could result in serious personal injury.

⚠ WARNING Do not attempt to modify this tool or create

accessories not recommended for use with this tool. Any such alteration or modification is misuse and could result in a hazardous condition leading to possible serious injury.

⚠ WARNING To prevent accidental starting that could cause serious personal injury, always remove the battery pack from the tool when assembling parts.

This brushless circular saw must be used only with the FLEX 24V series battery packs and chargers.

NOTICE: Please refer to the battery pack and charger manuals for detailed operating information.

SWITCH (FIG. 10)

To turn the tool “ON”, press and hold the lock-off button with your thumb, then squeeze the trigger switch with your finger. Release the lock-off button and continue to squeeze the trigger for continued operation.

To turn the tool “OFF”, release the trigger switch, which is spring loaded and will return to the off position automatically.

Your saw should be running at full speed BEFORE starting the cut, and turned off only AFTER completing the cut. To increase switch life, do not turn switch on and off while cutting.

Fig. 10

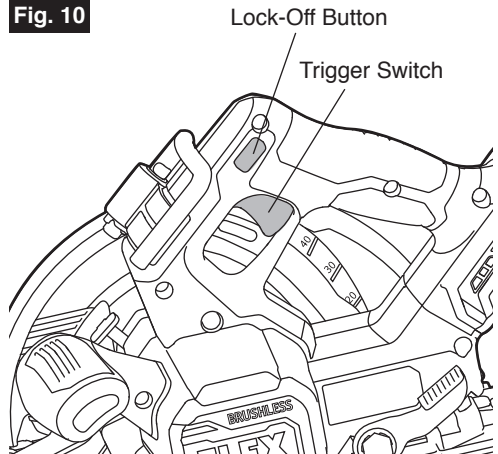

LED WORK LIGHT (FIG.11)

Your tool is equipped with the LED work light. This provides additional light on the saw blade and the surface of the workpiece for operation in lower-light areas.

The LED work light will automatically turn on with a slight squeeze of the trigger switch before the tool starts running. It will turn off approximately 10 seconds after the trigger switch is released.

- a. When the tool and/or battery pack becomes overloaded or too hot, the internal sensors will turn the tool off. If the tool and/or battery pack are overloaded, the LED light will rapidly flash. Rest the tool for a while or place the tool and battery pack separately under air flow for cooling.
- b. The LED light will flash more slowly to indicate that the battery pack charge is at low capacity. Recharge the battery pack.
- c. If the LED does not turn on when you start the tool, or it turns off suddenly during operation, please contact customer service or an authorised service centre for assistance.

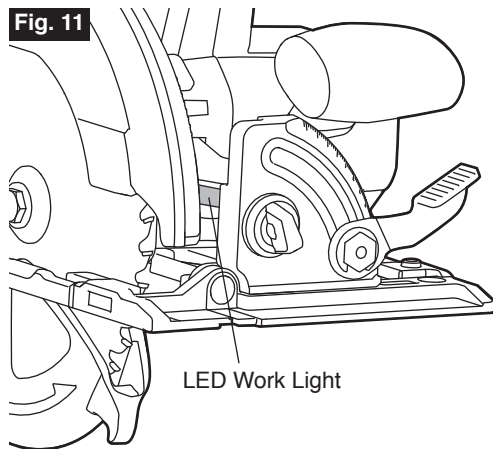

GENERAL CUTS

Always hold the saw by the main handle with one hand and the auxiliary handle with the other. Maintain a firm grip with both hands on the saw and position your arms to resist kickback forces. Position your body to either side of the blade, but not in line with the blade.

Make sure your body faces away from the vacuum hose adaptor.

⚠ WARNING Always be sure that neither hand interferes with the free movement of the lower guard.

Maintain a firm grip and operate the switch with a decisive action. Never force the saw. Use light and continuous pressure.

⚠ WARNING After completing a cut and releasing the trigger, be aware of the necessary time it takes for the blade to come to a complete stop during coast down. Do not allow the saw to brush against your leg or side; since the lower guard is retractable, it could catch on your clothing and expose the blade. Be aware of the necessary blade exposures that exist in both the upper and lower guard areas.

To resume cutting when cutting is interrupted, restart the saw, and allow the blade to reach full speed, re-enter the cut slowly, and resume cutting.

When cutting across the grain, the fibers of the wood tend to tear and lift. Advancing the saw slowly minimizes this effect. For a finished cut, a cross cut blade or miter blade is recommended.

PLUNGE CUTS (FIG. 12)

Remove the battery pack from the circular saw before making adjustments.

- Set the depth adjustment according to the thickness of the material to be cut. Attach the battery pack.
- Hold the main handle of the saw with one hand, tilt the saw forward, and rest the front of the foot plate on the material to be cut. Line up 0° mark on the foot with the line you've drawn. Use the lower-guard lift lever to raise the lower guard and hold the front of the foot plate with the other hand (Fig. 12).

Position the saw so that the blade is just clearing the material to be cut. Start the saw and, once it is fully up to speed, gradually lower the back end of saw using the front end of the foot as the hinge point.

Once the foot plate rests flat on the surface being cut, release the lower guard and move the hand holding the front of the foot plate to hold the auxiliary handle. Proceed cutting in forward direction to end of cut.

⚠ WARNING Allow blade to come to a complete stop before lifting the saw from the cut. Also, never pull

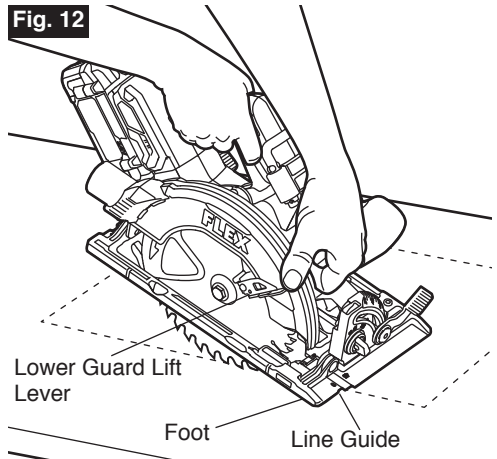

the saw backward, since blade will climb out of the material and KICKBACK will occur.

Turn the saw around and finish the cut in the normal manner, sawing forward. If corners of your plunge cut are not completely cut through, use a jig saw or hand saw to finish the corners.

CUTTING LARGE SHEETS (FIG. 13)

Large sheets and long boards can sag or bend, depending on their support. If you attempt to cut without leveling and properly supporting the piece, the blade will tend to bind, causing KICKBACK and extra load on the motor.

Support the panel or board close to the cut, as shown in (Fig. 13). Be sure to set the depth of the cut so that you cut through the sheet or board only and not the table or work bench.

The two-by-fours used to raise and support the work should be positioned so that the wide sides support the work and rest on the table or bench. Do not support the work with the narrow sides, as this is an unsteady arrangement. If the sheet or board to be cut is too large for a table or work bench, use the supporting two-by-fours on the floor and secure.

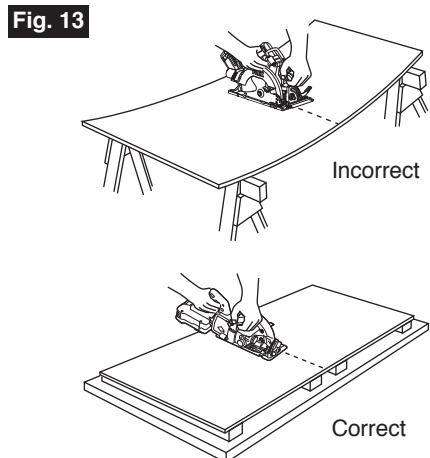

RIP CUTS (FIG. 14)

The blade provided with your saw is designed for both cross cuts and rip cuts. Ripping is cutting lengthwise with the grain of the wood. Rip cuts are easy to perform with a rip fence (Fig. 14). To attach a fence, insert the fence through the slots in the foot to the desired width, as shown, and secure it with the locking nut.

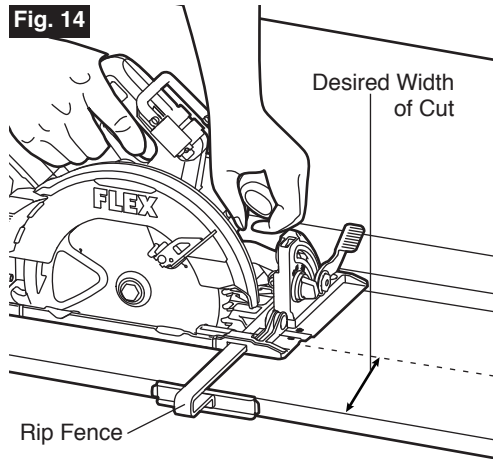

RIP-BOARD GUIDE (FIG. 15)

When rip cutting large sheets, the rip fence may not allow the desired width of cut.

Clamp or nail a straight piece of 25 mm timber to the sheet as a guide (Fig. 15). Use the right side of the foot against the board guide.

⚠ WARNING Ensure that the clamps do not interfere with the free movement of the saw.

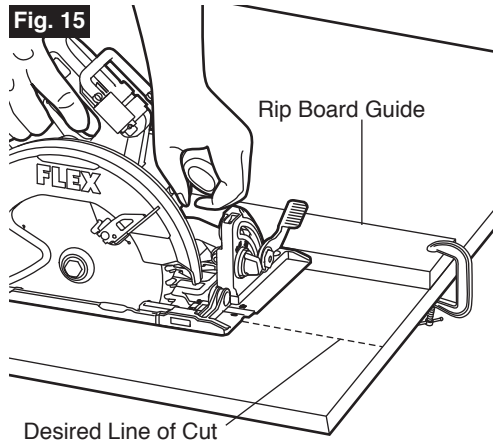

MAINTENANCE

⚠ WARNING To avoid serious personal injury, always remove the battery pack from the tool when cleaning or performing any maintenance.

SERVICE

⚠ WARNING Preventive maintenance performed by unauthorised personnel may result in misplacing of internal wires and components which could cause a serious hazard. We recommend that all tool service be performed by a FLEX Factory Service Centre or Authorised FLEX Service Station.

GENERAL MAINTENANCE

⚠ WARNING When servicing, use only identical replacement parts. Use of any other parts could create a hazard or cause product damage. Periodically inspect the entire product for damaged, missing, or loose parts such as screws, nuts, bolts, caps, etc. Tighten securely all fasteners and caps and do not operate this product until all missing or damaged parts are replaced. Please contact customer service or an authorised service centre for assistance.

CLEANING

⚠ WARNING The tool may be cleaned most effectively with compressed dry air. Always wear safety

goggles when cleaning tools with compressed air. Ventilation openings and switch levers must be kept clean and free of foreign matter. Do not attempt to clean by inserting pointed objects through openings.

⚠ WARNING Certain cleaning agents and solvents damage plastic parts. Some of these are: gasoline, carbon tetrachloride, chlorinated cleaning solvents, ammonia and household detergents that contain ammonia.

STORAGE

Store the tool indoors in a place that is inaccessible to children. Keep away from corrosive agents.

CARE OF BLADES

Blades become dull even from cutting regular timber. If you find yourself forcing the saw forward to cut instead of just guiding it through the cut, chances are the blade is dull or coated with wood pitch.

When cleaning gum and wood pitch from blade, detach the battery pack and remove the blade.

Remember, blades are designed to cut, so handle them carefully. Wear gloves and wipe the blade with kerosene or similar solvent to remove the gum and pitch.

Unless you are experienced in sharpening blades, we recommend you do not try.

ACCESSORIES

⚠ WARNING The use of any other accessories not specified in this manual may create a hazard.

Ø 184mm 24T FLEX Blade

Vacuum Adaptor & Lower Guard Lever

Blade Wrench

Rip Fence & Rip Fence Locking Nut

WARRANTY STATEMENT

Chervon Australia Pty Ltd (ABN 36 165 077 501) of Unit 14,5 Kelletts Road, Rowville, Victoria, 3178, and Chervon New Zealand Subsidiary Ltd (NZBN 9429049277616) (**Chervon**) provides the following warranty (**Warranty**) to original domestic purchasers in Australia and New Zealand as applicable (**Customers**) of its FLEX 24V Tools, FLEX 24V Batteries and Chargers and FLEX STACK PACK™ Storage System (collectively **Products**).

The benefits of this Warranty are in addition to any rights and remedies imposed by Australian State and Federal or New Zealand legislation that cannot be excluded. Nothing in this Warranty is to be interpreted as excluding, restricting or modifying any legislation relevant to the supply of goods and services in Australia or New Zealand, as applicable, which cannot be excluded, restricted or modified.

In Australia, if the claimant is a “consumer” under the *Australian Consumer Law*, Chervon confirms the following:

Our goods come with guarantees that cannot be excluded under the *Australian Consumer Law*. You are entitled to a replacement or refund for a major failure and compensation for any other reasonably foreseeable loss or damage. You are also entitled to have the goods repaired or replaced if the goods fail to be of acceptable quality and the failure does not amount to a major failure.

WARRANTY

Chervon warrants that, subject to the terms of this Warranty and the exclusions and limitations contained herein, the Products will be free from defects in materials and workmanship for the following period, as applicable, calculated from the date of purchase of the Product (**Warranty Period**):

- If the Customer registers its purchase of the Product online at www.flex-tools.com.au in Australia or www.flex-tools.co.nz in New Zealand within 30 days of the date of its purchase (**Registration**), the Warranty Period for the following Products is as follows
 - FLEX 24V Tools: 5 years;
 - FLEX 24V Batteries and Chargers: 5 years;
 - FLEX STACK PACK™ Storage System: 1 year;
 - FLEX Accessories & Consumables: 90 Days
- If the Customer fails to complete Registration as outlined above, the Warranty Period for the following Products is as follows:
 - FLEX 24V Tools: 3 years;
 - FLEX 24V Batteries and Chargers: 3 years;
 - FLEX STACK PACK™ Storage System: 1 year;
 - FLEX Accessories & Consumables: 90 Days

For further clarification and avoidance of doubt please refer to the FLEX product warranty table included below.

If, before the end of the Warranty Period, a defect appears in the manufacture or assembly of a Product, and Chervon finds the Product to be defective in materials or workmanship, it will, in its sole discretion, either:

- replace or repair the Product or the defective part of the Product free of charge; or
- cause the Product or the defective part of the Product to be replaced or repaired free of charge.

Chervon reserves the right to replace a defective Product or part of a Product with parts and components of similar quality, grade and composition where an identical part or component is not available. Where the product is repaired, Chervon may use refurbished parts.

WARRANTY CLAIMS

1. If a defect covered by Warranty appears, you must first contact Chervon:
 - (a) by telephone on 1300 000 346 (AU); or 0508 000 346 (NZ); or
 - (b) by email at support@flex-tools.com.au.
2. Any Warranty claim must be accompanied by:
 - (a) proof of purchase;
 - (b) full details of the alleged defect;
 - (c) photo evidence of the alleged defect; and
 - (d) any other relevant documents.
3. You must allow Chervon or its authorised agent to inspect and test the Product. If that inspection and test finds no defect in the Product, you must pay Chervon's usual service and testing costs.
4. Unless otherwise agreed in writing by Chervon, you must pay the cost of transporting the Product to and from Chervon or Chervon's authorised agent and any related insurance cost. Any handling and transportation costs (and other expenses incurred in claiming this warranty) are not covered by this warranty and will not be borne by Chervon.
5. The replacement product or part, or repaired product will be made available for your collection at an address nominated by Chervon.
6. Customers are responsible for the care and cleaning of their product prior to sending it to back to Chervon or its nominated authorised repair agents. Any product being sent for repair must be cleaned. It is an Occupational/Work Health and Safety risk for our staff or authorised repairers to inspect, repair or service a product that has come into contact with a hazardous substance.
7. If Chervon or its authorised repair agent is to inspect, repair or service a product that has come into contact with a hazardous substance such as asbestos, silica dust or other hazardous substance then we may not be able to inspect, service or repair the product. If this is the case, Chervon reserves the right to refuse repair under these circumstances and will inform the customer and the product will be returned at the customer's expense.

EXCLUSIONS

The Warranty does not apply if:

- (a) the Product is not supplied in its final shape and form by Chervon or an authorised FLEX Dealer, which can be confirmed on the website store locator (for avoidance of doubt, third party online stores such as eBay, Gumtree, Amazon, etc. are excluded);
- (b) the Product is altered, modified or repaired by a party other than Chervon or its agent;
- (c) the Product is used other than for its designed purpose;
- (d) the Product is used for rental purposes
- (e) the Product is used or installed other than in accordance with Chervon's instructions;
- (f) the Product has not been maintained or protected in accordance with Chervon's instructions;
- (g) the Product has been subject to abnormal conditions;
- (h) the product suffers normal deterioration of the exterior finish, including but not limited to scratches, dents, paint chips, or to any corrosion or discolouring by heat, abrasive and chemical cleaners.
- (i) the Product is involved in an accident;
- (j) Chervon cannot find any defect in the Product after testing, inspection and assessment;

- (k) the alleged defect is due to abuse, misuse, neglect (including failure to clean) or accident;
- (l) the alleged defect is due to a failure to properly maintain or use the Product;
- (m) the alleged defect in the Product is within acceptable industry standards or tolerances; or
- (n) the alleged defect is due to a request to customise the Product.
- (o) the alleged defect is due to normal wear and tear, misuse or abuse (including overloading of the product beyond capacity and exposure to water or rain)
- (p) The alleged defect has been used or caused due to continuous industrial use

The Warranty does not extend to:

- (a) damage or defects caused by normal wear and tear;
- (b) the Products being damaged by you or a third party;
- (c) accidental or wilful damage, or misuse; or
- (d) theft or vandalism.

This Warranty does not extend to other accessories or attachments.

LIMITATIONS

Chervon makes no express warranties or representations other than as set out in this document. Chervon will not be liable to you or any other person in connection with this Warranty for any:

- (a) consequential or indirect loss, damage or costs incurred by you or any other person; or
- (b) damage to property, loss of turnover, loss of profits, loss of business or loss of good will.

CONTACT

For Warranty Service or to make a claim please contact Chervon on the details below between the hours of Monday to Friday 9:00am to 5:00pm AEST/NZST (as applicable)

Chervon Australia Pty Ltd

Unit 14, 5 Kelletts Rd, Rowville, VIC. 3178.

Ph Australia; 1300 000 346. Email: support@flex-tools.com.au

Chervon New Zealand Subsidiary Ltd

4th Floor, Smith & Caughey Building, 253 Queen St, Auckland, 1141.

Ph New Zealand; 0508 000 346. Email: support@flex-tools.com.au

WARRANTY TYPE	LIMITED STANDARD WARRANTY PERIOD	LIMITED EXTENDED WARRANTY PERIOD
CONDITIONS	Without Registration / OR Registration after 30 days from date of purchase	Registration within 30 days from date of purchase
FLEX 24V Power Tools	3 Years	5 Years
FLEX 24V Chargers	3 Years	5 Years
FLEX 24V Lithium-ion Batteries	3 Years	5 Years
FLEX Accessories & Consumables	90 Days	
FLEX STACK PACK™ Storage System	1 Year	

*Original purchaser must register the product(s) within 30 days of purchase and retain their receipt as proof of purchase. This warranty applies only to the original purchaser from an authorised FLEX dealer and may not be transferred. If original purchaser does not register their product within 30 days, the warranty will apply for the duration set out in table above in column "LIMITED STANDARD WARRANTY PERIOD". For avoidance of doubt please refer to warranty table above and full warranty details in this manual or on our website at www.flex-tools.com.au